

SICIS[®]
HOME COLLECTION

**RIALTO
KITCHEN**

MADE IN ITALY

RIALTO KITCHEN

SICIS presenta la prima cucina nata all'interno della collezione Home.

L'arte del mosaico e l'arte della cucina, apparentemente distinte e lontane, condividono un legame intrinseco che risiede nella loro essenza creativa e nell'attenzione al dettaglio. Entrambe queste forme di espressione artistica nascono da una combinazione armoniosa di elementi per creare un'opera che colpisca i sensi e l'anima. Il mosaico attraverso le sue tessere variopinte e minuziosamente posizionate, è simbolo di pazienza e di precisione. Ogni piccolo frammento è parte di un disegno più grande, una composizione che si svela solo quando tutte le parti sono unite. Allo stesso modo, l'arte culinaria combina ingredienti differenti, ciascuno con la propria consistenza, colore e sapore, per creare un piatto finale che è più della somma delle sue parti.

Il legame tra mosaico e cucina si manifesta anche nella loro capacità di raccontare storie e culture. Ogni mosaico narra vicende attraverso le sue immagini e motivi, così come ogni piatto racconta la storia di una tradizione culinaria, riflettendo l'identità e l'anima di un luogo.

Così, nell'esplorare il legame tra l'arte del mosaico e l'arte della cucina, scopriamo un mondo dove la bellezza visiva e quella gustativa si intrecciano, creando un'esperienza sensoriale unica che celebra la creatività umana in tutte le sue forme.

La conoscenza approfondita dei materiali così applicata delle tecniche di lavorazione e del design acquisita nella produzione di mosaici, si rivela pratica illuminante e feconda nella creazione dello spazio cucina, nella selezione e combinazione di materiali diversi e innovativi, dove qualità ed estetica si fondono per soluzioni attraenti e funzionali.

SICIS presents the first kitchen born within the Home collection. The art of mosaic and the art of cooking, seemingly distinct and distant, share an intrinsic bond rooted in their creative essence and attention to detail. Both of these forms of artistic expression arise from a harmonious combination of elements to create a work that impacts the senses and the soul. Mosaic, through its meticulously placed colorful tiles, symbolizes patience and precision. Each small fragment is part of a larger design, a composition that is revealed only when all parts are united. Similarly, the culinary art combines different ingredients, each with its own texture, color, and flavor, to create a final dish that is more than the sum of its parts. The connection between mosaic and cuisine also manifests in their ability to tell stories and cultures. Each mosaic narrates tales through its images and motifs, just as each dish tells the story of a culinary tradition, reflecting the identity and soul of a place. Thus, in exploring the link between the art of mosaic and the art of cooking, we discover a world where visual and taste beauty intertwine, creating a unique sensory experience that celebrates human creativity in all its forms. The in-depth knowledge of materials, applied techniques, and design acquired in the production of mosaics proves to be illuminating and fruitful in creating the kitchen space. This involves the selection and combination of different and innovative materials, where quality and aesthetics merge for attractive and functional solutions.





CONCEPT

RIALTO, un progetto che si esprime attraverso un segno geometrico addolcito da rotondità funzionali e grande attenzione alle proporzioni dove l'eccellenza della qualità italiana sposa l'innovazione e la scelta di materiali inediti e originali.

Un programma che prevede grande componibilità con composizioni e soluzioni su misura, pensato per rispondere alle più esigenti richieste dei clienti internazionali.

L'originalità degli inserti in Vetríte, del metallo in finitura champagne satinato e della cannettatura in legno lavorato artigianalmente mostrano una nuova idea di lusso internazionale. Le molteplici possibilità di finiture, soprattutto per quello che riguarda la Vetríte permettono di presentarla sempre in nuova veste.

Protagonista assoluto è l'isola centrale che si contraddistingue per le sue forme morbide e sinuose. Le numerose alternative di componibilità contribuiscono alla modularità progettuale della cucina Sicis. Ad arricchire l'isola centrale è la possibilità di inserire un tavolo a sbalzo, disponibile in forma rotonda o ellissoidale, che ruota su un perno centrale per dare maggiore spazio alla convivialità.

Il programma RIALTO prevede un ampio sistema di colonne, basi e pensili personalizzabili pensate per la preparazione e per il contenimento. Le ante delle colonne, con un morbido movimento scorrono lateralmente, svelando un ampio spazio funzionale al loro interno. Gli schienali in vetrite retroilluminata rendono tutte composizioni ricche di personalità e originalità, caratteristiche che da sempre contraddistinguono i prodotti SICIS.

RIALTO a project that is expressed through a geometric signs of tened by functional roundness and great at tention to proportions where the excel lence of Italian quality marries innovation and the choice of new and original materials

A program that offers great modularity with customizable compositions and solutions, designed to meet the most demanding requests of international clients. The originality of the inserts in Vetríte, the metal in satin champagne finish, and the handcrafted wood cannature show a new idea of international luxury. The multiple finishing possibilities, especially regarding Vetríte, allow it to be presented in a new guise every time. The absolute protagonist is the central island, which stands out for its soft and sinuous shapes. The numerous options for customization contribute to the modular design of the Sicis kitchen. To enrich the central island, there is the possibility of adding a cantilever table, available in round or ellipsoidal shape, which rotates on a central pivot to provide more space for conviviality. The RIALTO program features a wide system of customizable columns, bases, and wall units designed for preparation and containment. The column doors, with a smooth lateral movement, slide to the side, revealing a spacious functional space inside. The back panels in backlit glass make all compositions rich in personality and originality, characteristics that have always distinguished SICIS products.

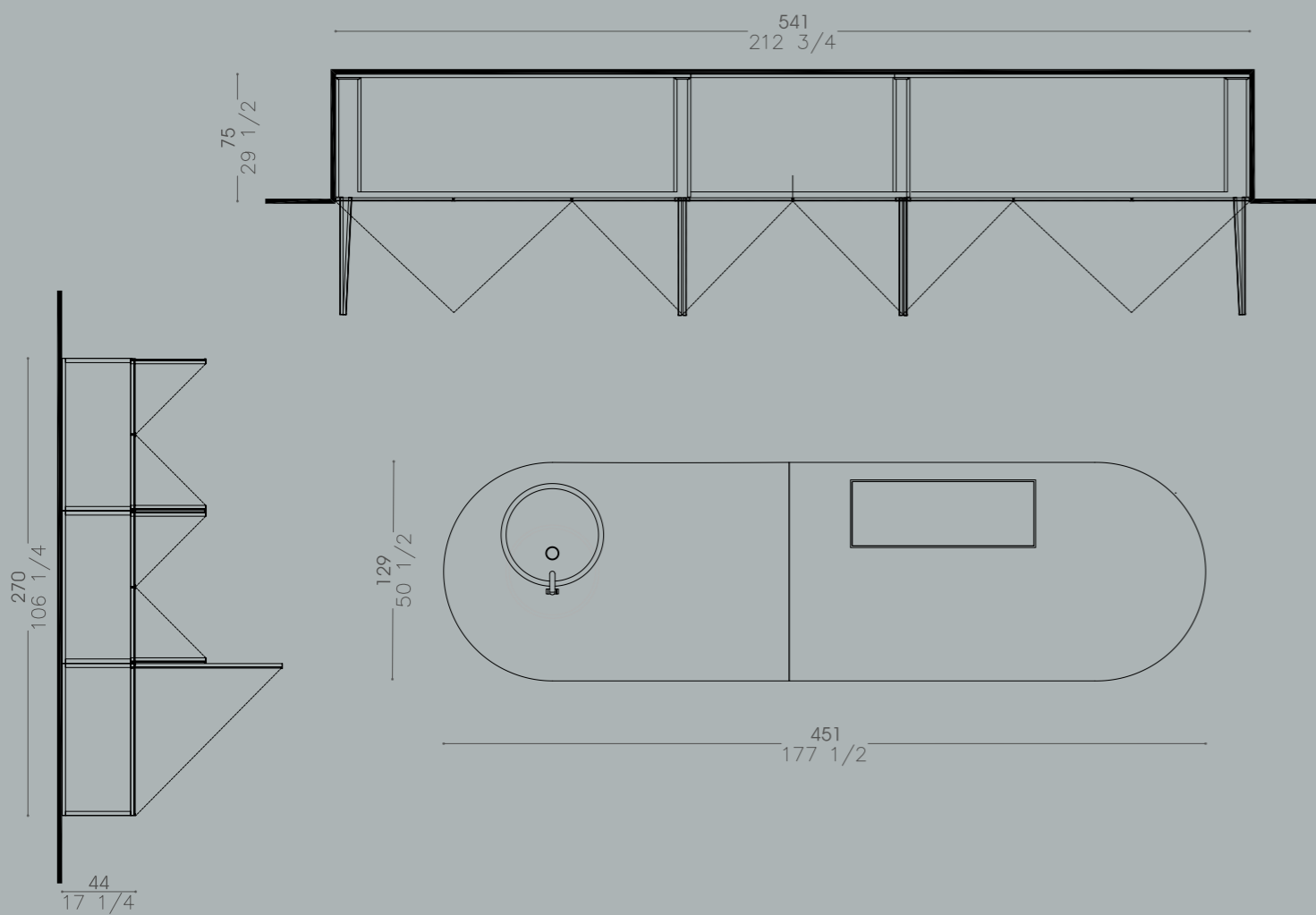

CAPITOLO 1

Colonne con anta a scomparsa cannettata wave con cornice metallica | essenza olmo moka opaco | metallo champagne lucido | vetrite onigem giada | modulo doppio con interno modulo forno | 2 modulo triplo con interno ante battente e mensole

Isola centrale RI.PC.02 SX con lavello rotondo diametro 55 cm + RI.PCM.04 DX con piano cottura a induzione |

Vetrinetta sospesa grande con ante rete metallica e cornice metallica

CHAPTER 1

Columns with retractable ribbed wave door with metal frame | matte elm moka wood | champagne polished metal | onigem giada vetrite | double module with internal oven module | 2 triple modules with internal hinged doors and shelves |

Central island RI.PC.02 SX with round sink diameter 55 cm + RI.PCM.04 DX with induction cooktop |

Wall cabinet large suspended display case with glass doors with mesh and metal frame

| 01







- 01** vetrite onigem giada
onigem giada vetrite
- 02** tessere velluto elios smoky
tessere elios smoky velvet
- 03** metallo champagne lucido
champagne polished metal
- 04** cannettato wave | essenza olmo moka opaco
ribbed wave | matte elm moka wood
- 05** vetro con rete
glass with mesh





Dettaglio del cassetto con rivestimento in Vetrite e maniglia metallica in finitura champagne lucido

Detail of the drawer with Vetrite coating and metal handle in polished champagne finish





Il programma RIALTO prevede la personalizzazione di ogni singolo dettaglio.
La rubinetteria è resa unica con l'inserimento della Vetrite

*The RIALTO program involves the customization of every single detail.
The uniqueness of the faucet is enhanced by the addition of Vetrite inserts.*



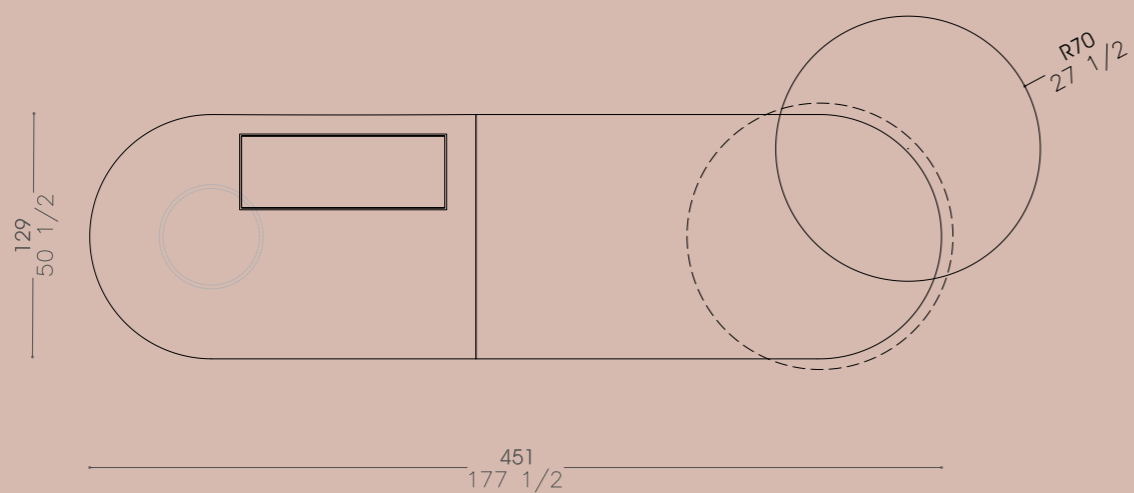
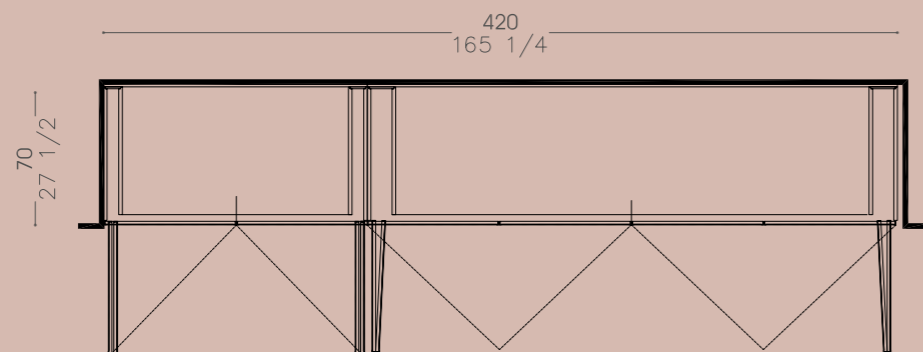

CAPITOLO 2

Colonne con anta cannettata wave a scomparsa con cornice metallica | essenza ebano ammara opaco | metallo champagne lucido | ante a scomparsa in vetrite con cornice metallica | vetrite elephant calima | metallo champagne lucido | modulo doppio con interno modulo forno | modulo quadruplo con interno ante battente e pensili in metallo | vetrite gem glass crystallised con retroilluminazione |

Isola centrale RI.PCM.03 SX con piano cottura a induzione + RI.PCM.03 DX con tavolo rotondo diametro 140cm

CHAPTER 2

Columns with retractable ribbed wave door with metal frame | matte ammara ebony wood | champagne polished metal | retractable doors in vetrite with metal frame | elephant calima vetrite | champagne polished metal | double module with internal oven module | quadruple module with hinged doors and metal wall units | crystallised gem glass vetrite with back-lighting |

Central island RI.PCM.03 SX with induction hob + RI.PCM.03 DX with round table diameter 140cm







L'alta qualità e attenzione ai dettagli si riflette in ogni elemento della cucina
The high quality and attention to detail is reflected in every element of the kitchen







- 01** cannettato wave | essenza ebano ammara opaco
ribbed wave | matte ammara ebony wood
- 02** vetrite elephant calima
elephant calima vetrite
- 03** essenza ebano ammara opaco
matte ammara ebony wood
- 04** metallo champagne lucido
champagne polished metal
- 05** vetrite gem glass crystallised
gem glass crystallised vetrite
- 06** vetro con rete
glass with mesh
- 07** velluto tessere elios almond
tessere elios almond velvet



Il tavolo a sbalzo di RIALTO crea un ambiente ideale per condividere un pasto, unendo funzionalità e convivialità

RIALTO's cantilevered table is the ideal place to share a meal, combining functionality and conviviality.



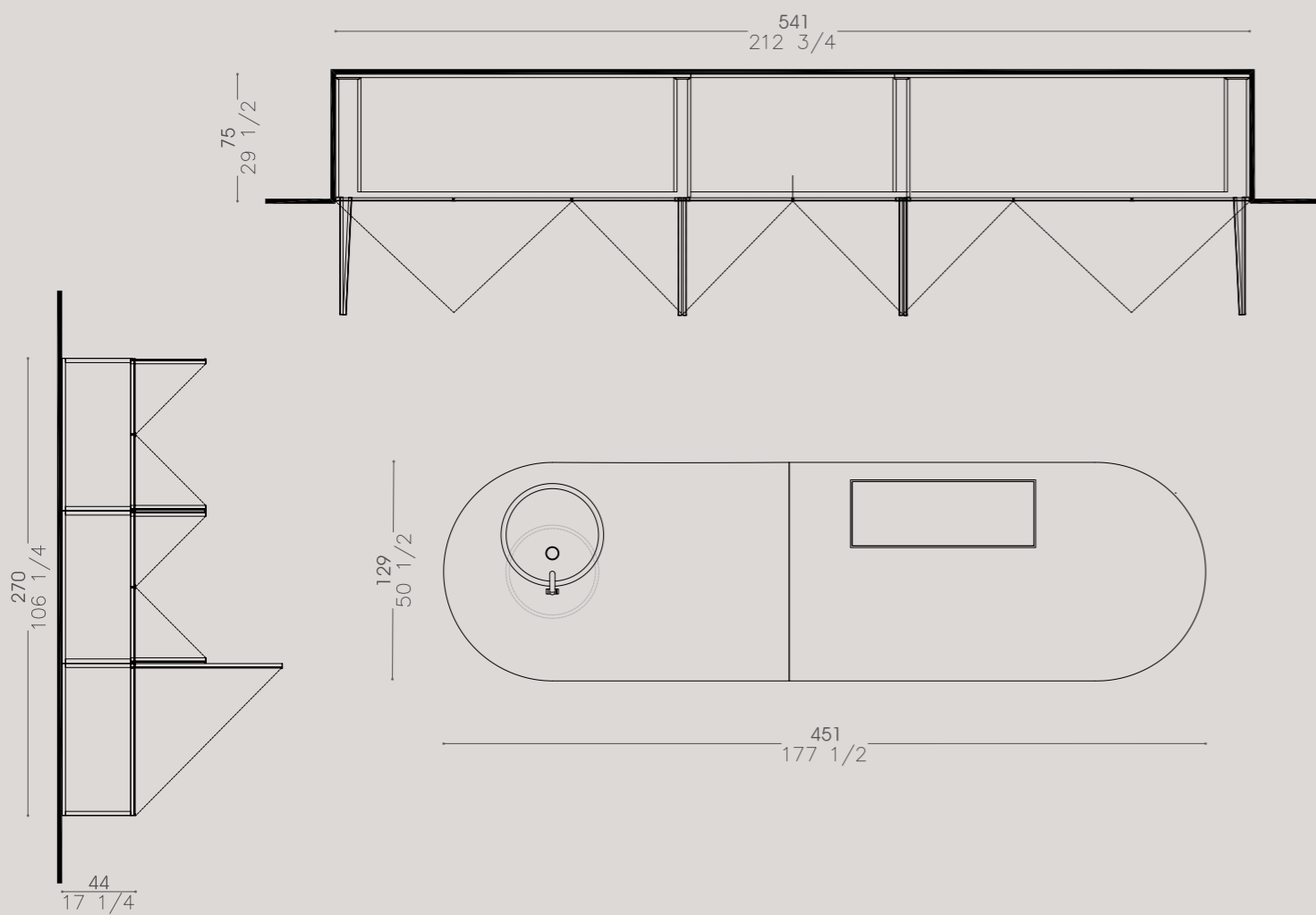

CAPITOLO 3

Colonne con anta cannettata wave a scomparsa con maniglia metallica | essenza rovere miele | metallo champagne lucido | vetrite gem stone streetwalk con retroilluminazione | modulo doppio con interno modulo forno | 2 modulo triplo con interno ante battente e mensole |

Isola centrale RI.PC.02 SX con lavello rotondo diametro 55 cm + RI.PCM.04 DX con piano cottura a induzione |

Vetrinetta sospesa grande con ante rete e cornice metallica

CHAPTER 3

Columns with retractable wave ribbed door with metal handle | honey oak wood | champagne polished metal | gem stone streetwalk vetrite with backlighting | double module with internal oven module | 2 triple module with internal hinged doors and shelves |

Central island RI.PC.02 SX with round sink diameter 55 cm + RI.PCM.04 DX with induction cooktop |

Wall cabinet large suspended display case with glass doors with mesh and metal frame

| 03

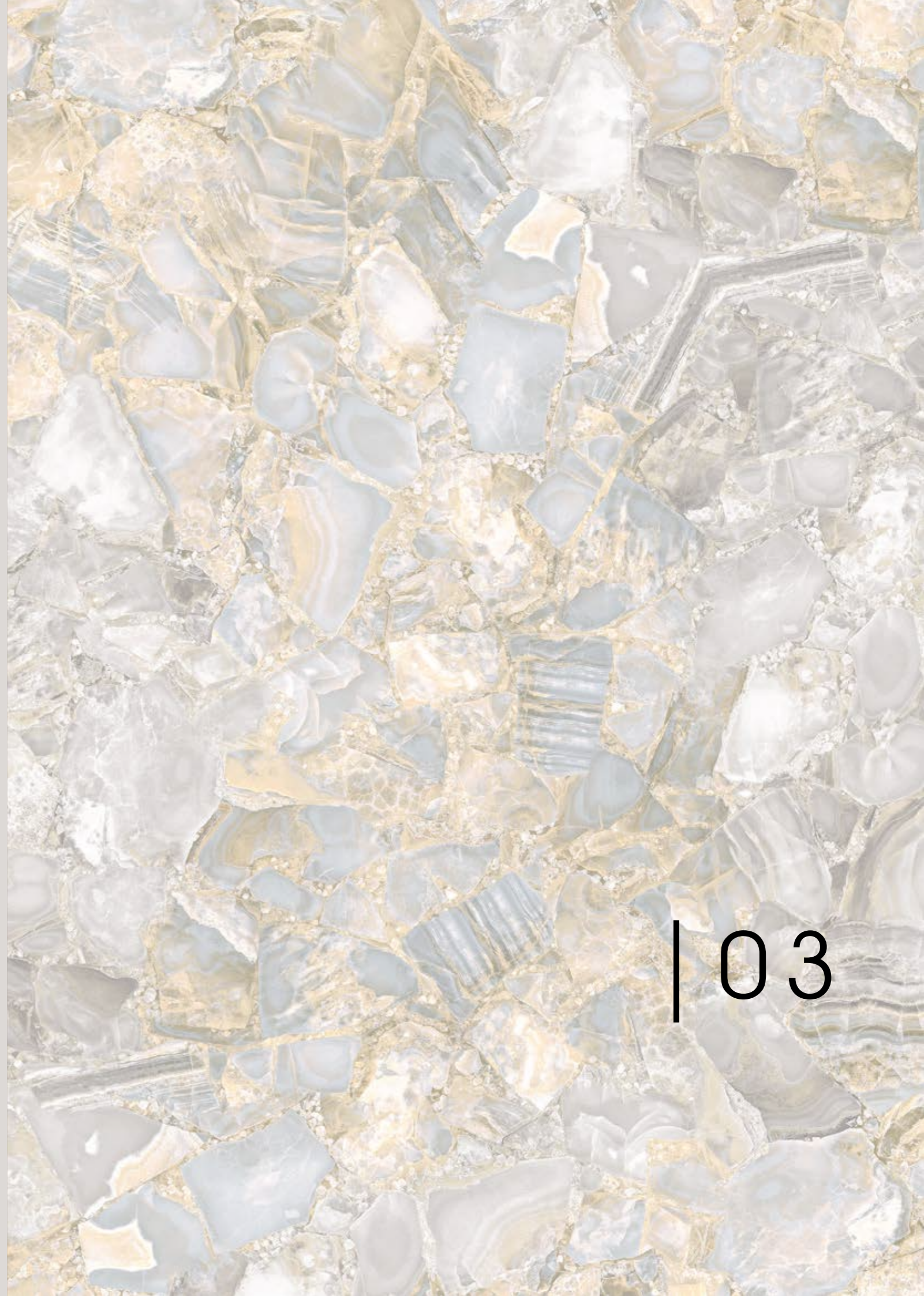







Le forme sinuose e i dettagli in Vetrite definiscono l'isola centrale di Rialto, creando un punto focale di eleganza e funzionalità.

The sinuous shapes and Vetrite details define Rialto's central island, creating a focal point of elegance and functionality.

01



02



05

03

04

- 01** vetrite gem stone streetwalk
gem stone streetwalk vetrite
- 02** velluto tessere elios black
tessere elios black velvet
- 03** metallo champagne lucido
champagne polished metal
- 04** vetro con rete
glass with mesh
- 05** cannettato wave | essenza rovere miele
ribbed wave | honey oak wood





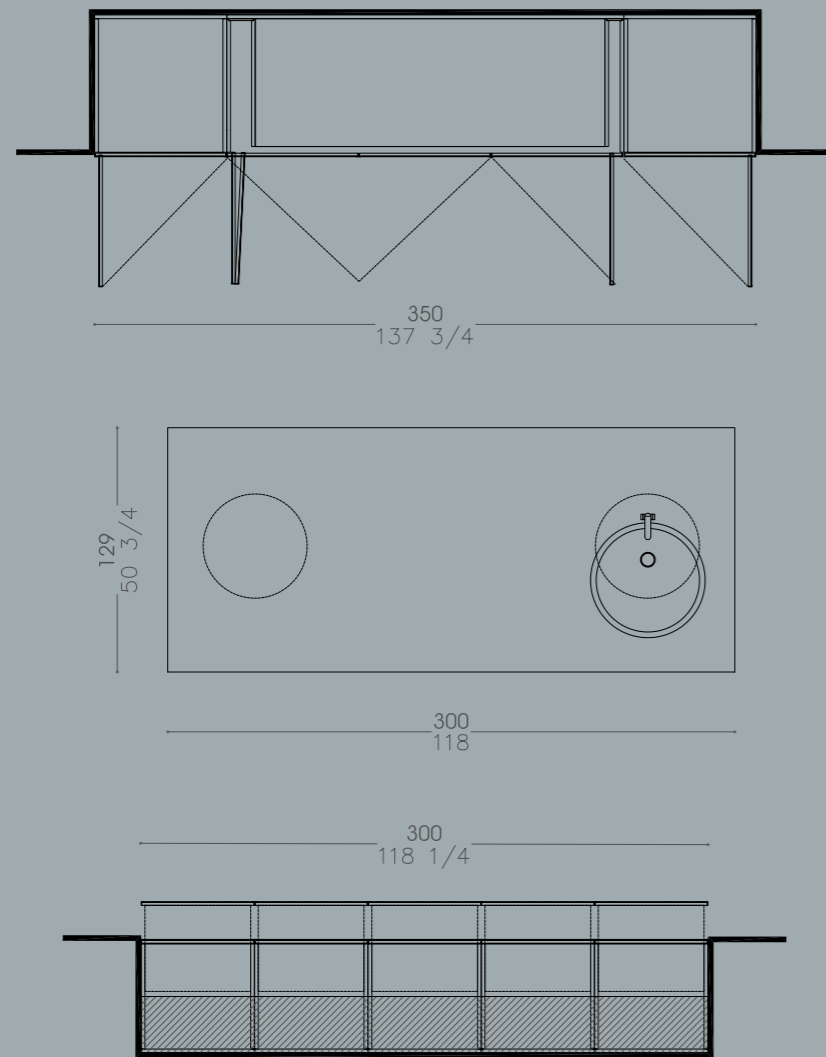

CAPITOLO 4

Colonne con anta cannettata line a battente con maniglia metallica | essenza rovere nero opaco | metallo champagne lucido | anta a scomparsa in vetro con rete con profilo metallico | vetrite gem stone noire | modulo triplo con interno ante battente e mensole | 2 modulo singolo con interno frigorifero e congelatore |
Isola centrale RI.ISR.02 con lavello rotondo diametro 55 cm | **Basi 60** con 2 cassetti | essenza rovere nero opaco | **Pensili 60** con anta battente | metallo champagne lucido | **Top e backsplash** in vetrite gem stone noire

CHAPTER 4

Columns with ribbed line hinged door with metal handle | matte black oak wood | champagne polished metal | retractable doors in glass with mesh and metal profile | gem stone noire vetrite | triple module with internal hinged doors and shelves | 2 single module with internal fridge and freezer |
Central island RI.ISR.02 with round sink diameter 55 cm with | **60 bases** with 2 drawers | matte black oak wood | **Wall unit 60** with hinged door | champagne polished metal | **Top and backsplash** in gem stone noire vetrite

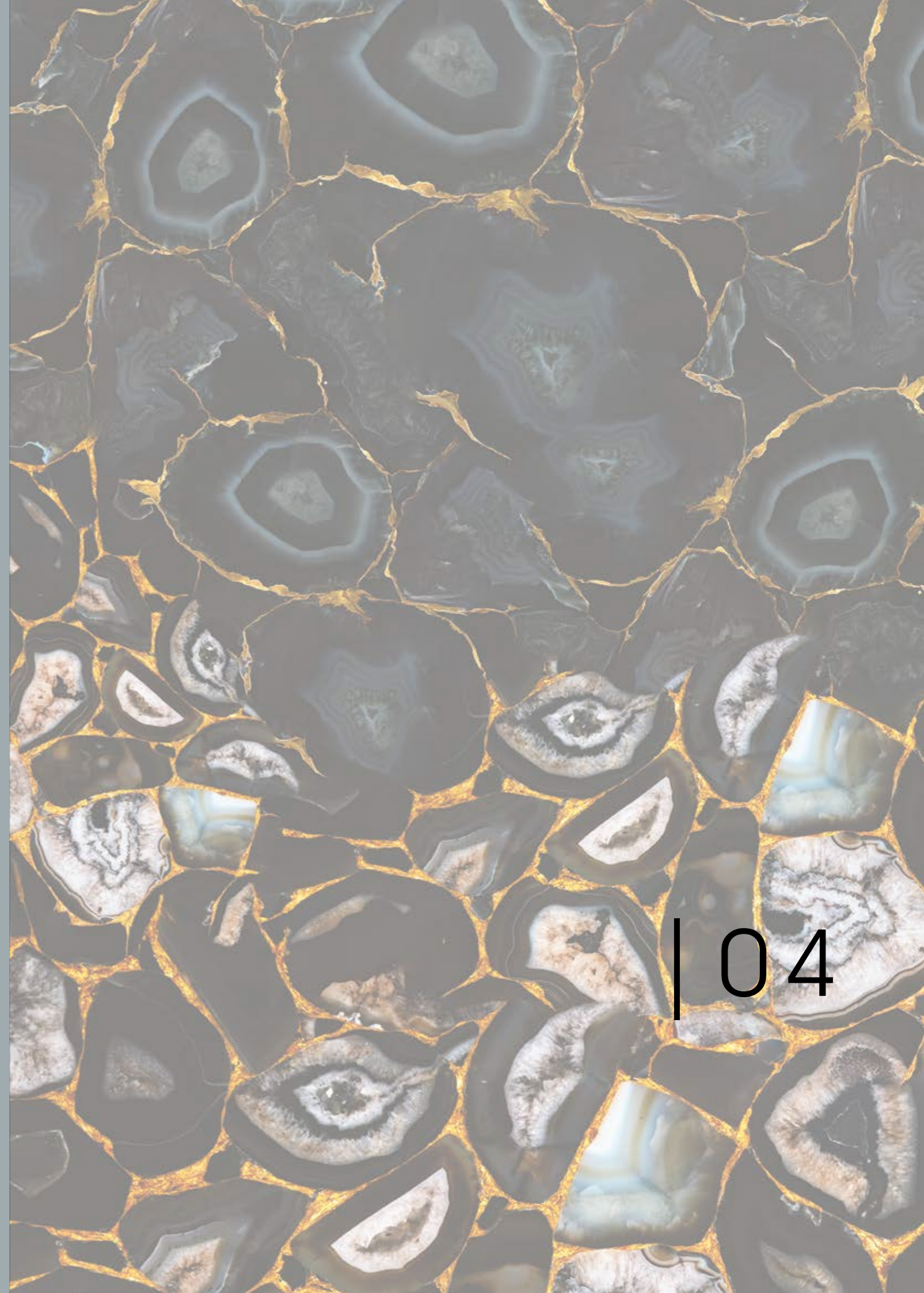



01



- 01** cannettato line | essenza rovere nero opaco
ribbed line | matte black oak wood
- 02** vetrite elephant calima
elephant calima vetrite
- 03** vetro con rete
glass with mesh
- 04** vetrite gem stone noire
gem stone noire vetrite
- 05** metallo champagne lucido
champagne polished metal
- 06** nabuk tessere vermont smoky
tessere vermont smoky nubuck

05
04







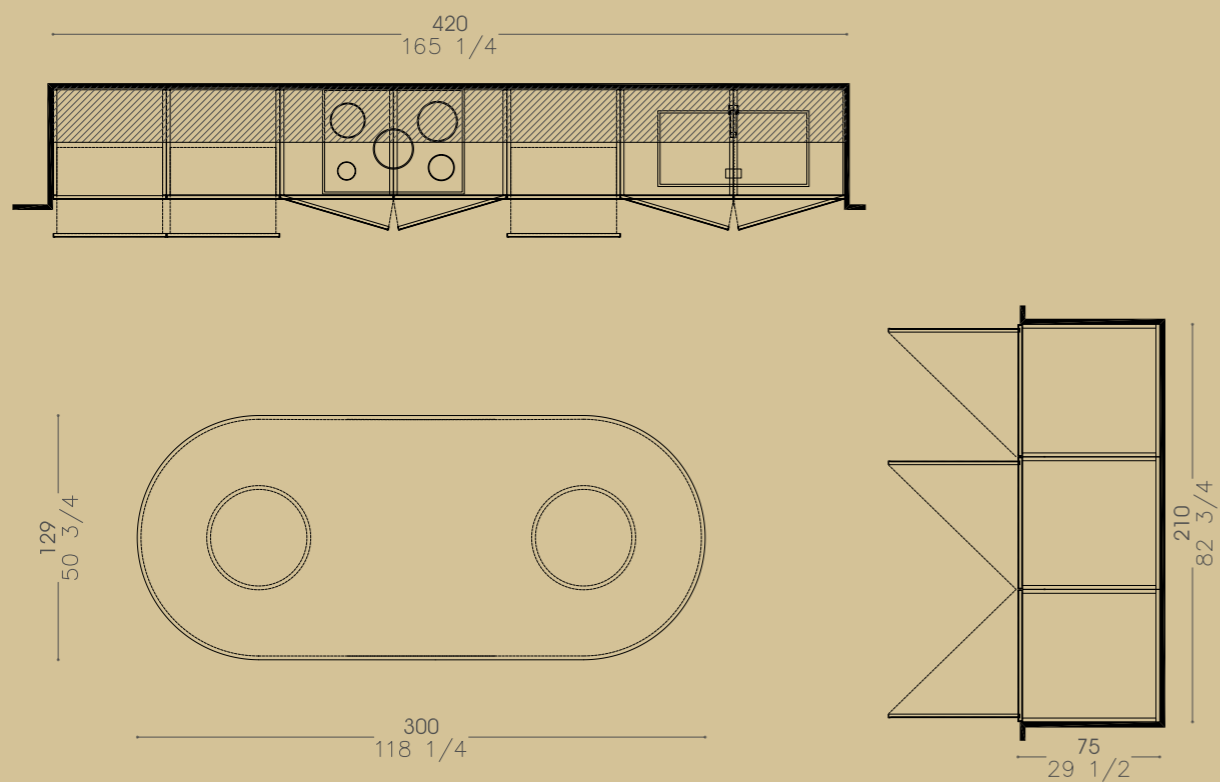

CAPITOLO 5

Colonne 2 modulo singolo con interno mensole | anta a battente in vetro con rete cornice metallica | 1 modulo singolo con modulo forno | ante a battente in vetrite onigem sable cornice metallica | metallo champagne lucido |

Basi 60 anta battente | essenza rovere grigio opaco | **Pensili 120/60** con anta ribalta | metallo champagne lucido |

Isola centrale RI.ISC.01

CHAPTER 5

Columns 2 single module with internal shelves | hinged door in glass with mesh and metal profile | 1 single module with oven module | hinged doors in onigem avory vetrite with metal frame | champagne polished metal |

Bases 60 swing door | matte gray oak wood | **Wall units 120/60** with flap opening door | champagne polished metal |

Central island RI.ISC.01







- 01** velluto tessere elios black
tessere elios black velvet
- 02** vetrite onigem avory
onigem avory vetrite
- 03** vetro con rete e cornice metallica
glass with mesh and metal profile
- 04** metallo champagne lucido
champagne polished metal
- 05** cannettato line | essenza rovere sabbia
ribbed line | matte sand oak wood





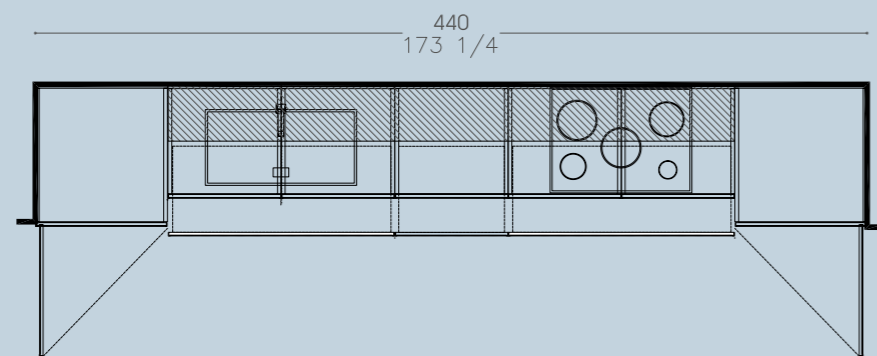

CAPITOLO 6

Colonne 70 modulo singolo con interno frigorifero | anta a battente nero laccato lucido | **Basi 120/60** con 2 cassetti | nero laccato lucido | **Pensili 120/60** con anta ribalta | vetro con rete profilo metallico | metallo bronzo lucido | **Pensili 120/60** profondità 60cm | nero laccato lucido | **Top e backplash** vetrite gem glass neve

CHAPTER 6

Columns 70 single module with internal refrigerator | polished black lacquered hinged door | **Bases 120/60** with 2 drawers | polished black lacquered | **Wall units 120/60** with flap opening door | glass with mesh and metal profile | bronze polished metal | **Wall units 120/60** depth 60cm | polished black lacquered | **Top and backplash** gem glass neve vetrite





01

02

03

04

05

04

05

06

07

- 01** vetrite onigem pink
pink onigem vetrite
- 02** laccato nero lucido
polished black lacquered
- 03** vetro con rete
glass with mesh
- 04** vetrite electric marble turchese
turchese electric marble vetrite
- 05** metallo bronzo lucido
bronze polished metal
- 06** tessere pelle oregon cream
tessere oregon cream leather
- 07** vetrite gem glass neve
gem glass neve vetrite





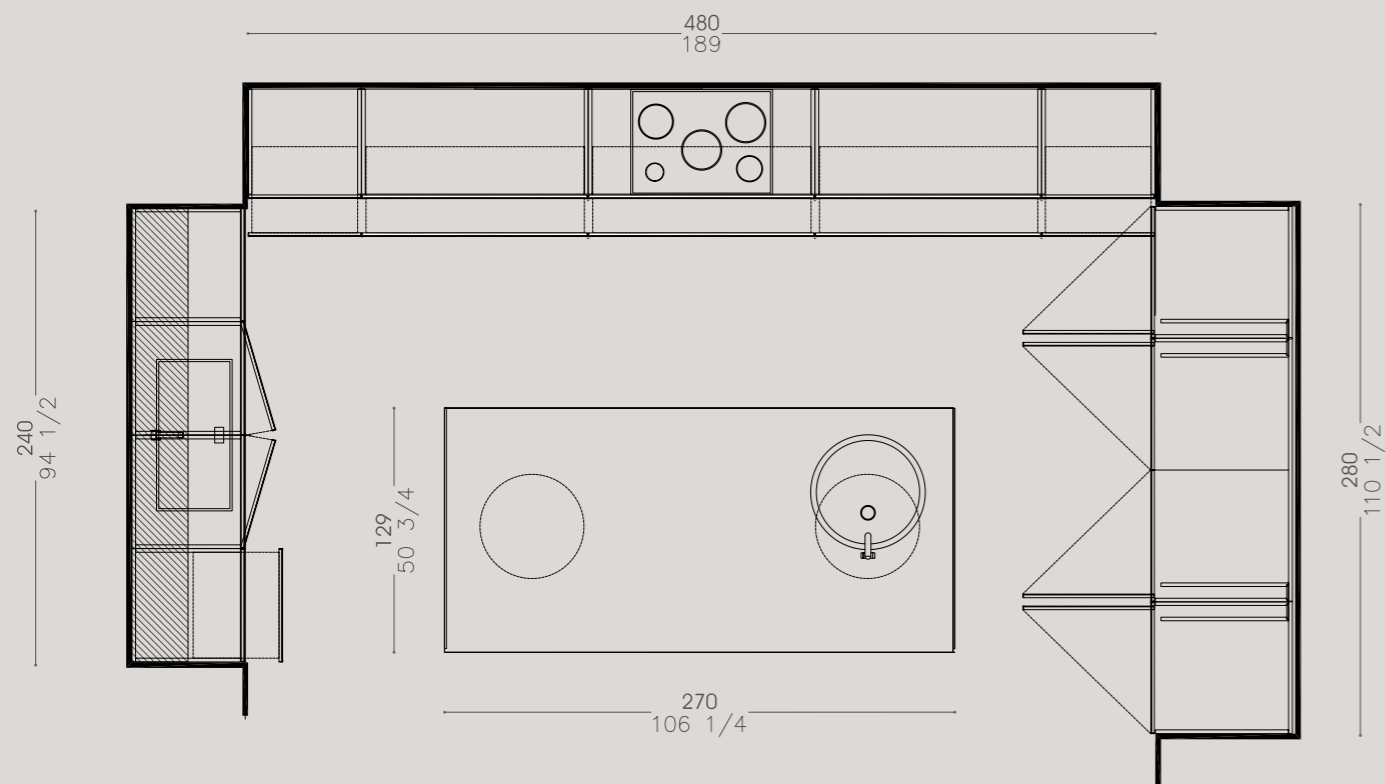

CAPITOLO 7

Colonne con anta cannettata line a scomparsa con profilo metallico | bianco laccato lucido | metallo champagne lucido | anta a scomparsa in vetro con rete con profilo metallico | modulo doppio con interno mensole | schienale interno con vetrite tela brown |

Basi 60 con 2 cassetti | bianco laccato lucido | **Basi 60** con anta a battente | bianco laccato lucido | **Pensili 60** con anta a battente | vetrite tela brown | **Pensili 60** con anta a battente in vetro con rete con profilo metallico | **Top** vetrite tela brown | **Isola centrale** RI.ISR.01 con lavello rotondo diametro 55 cm | **Backsplash** mosaico artistico

CHAPTER 1

Columns with line retractable ribbed door with metal profile | polished white lacquered | champagne polished metal | retractable door in glass with mesh and metal profile | double module with internal shelves | internal back with tela brown vetrite |

Bases 60 with 2 drawers | polished white lacquered | **Bases 60** with swing door | polished white lacquered | **Wall units 60** with hinged door | tela brown vetrite | **Wall units 60** with hinged door in glass with mesh and metal profile | **Top** tela brown vetrite | **Central island** RI.ISR.01 with round sink diameter 55 cm | **Backsplash** artistic mosaic





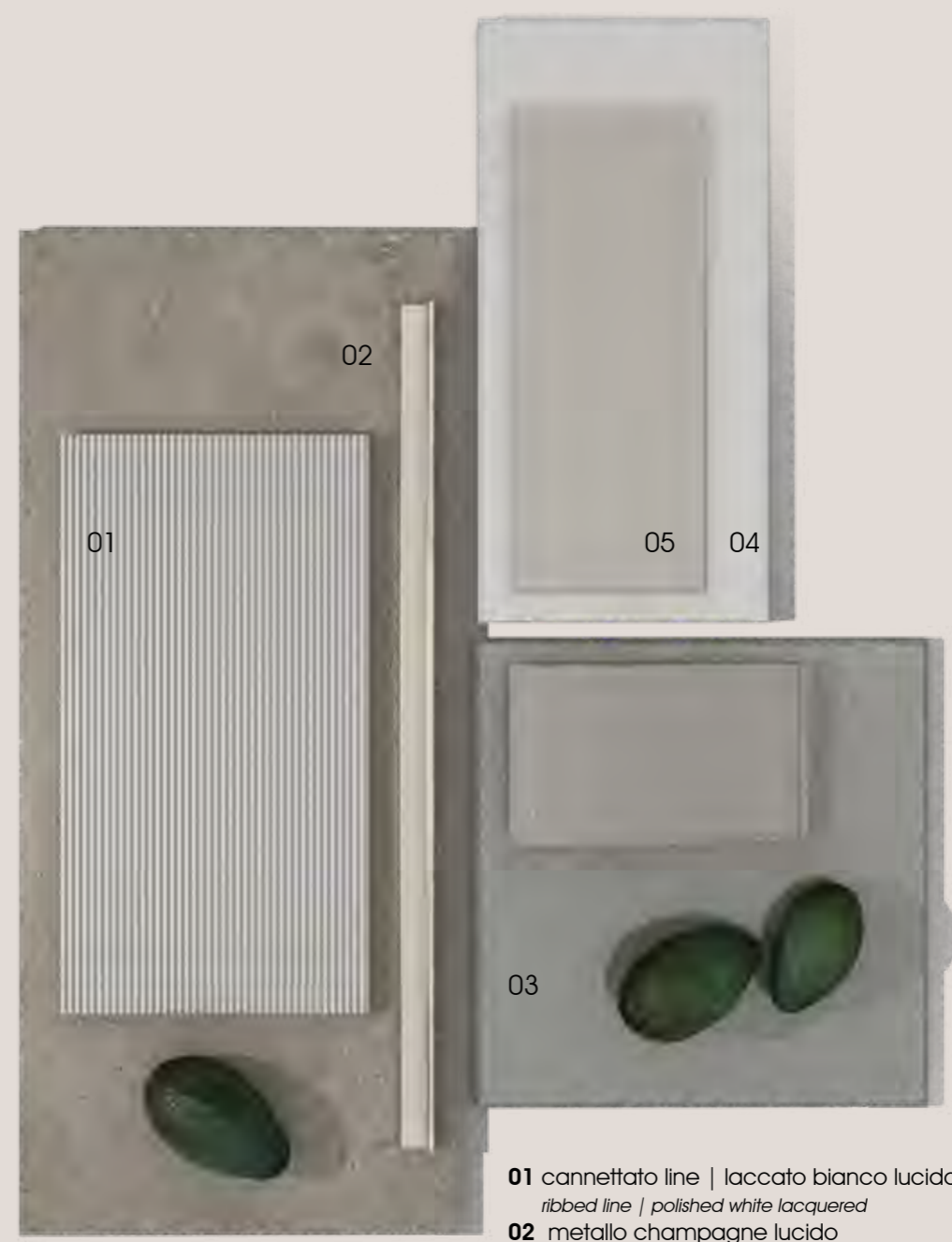

- 01** cannettato line | laccato bianco lucido
ribbed line | polished white lacquered
- 02** metallo champagne lucido
champagne polished metal
- 03** vetrite tela brown
tela brown vetrite
- 04** laccato bianco lucido
polished white lacquered
- 05** vetro con rete
glass with mesh





Il backsplash può essere personalizzato con il rivestimento in mosaico artistico

The backsplash can be customized with artistic mosaic tiling.



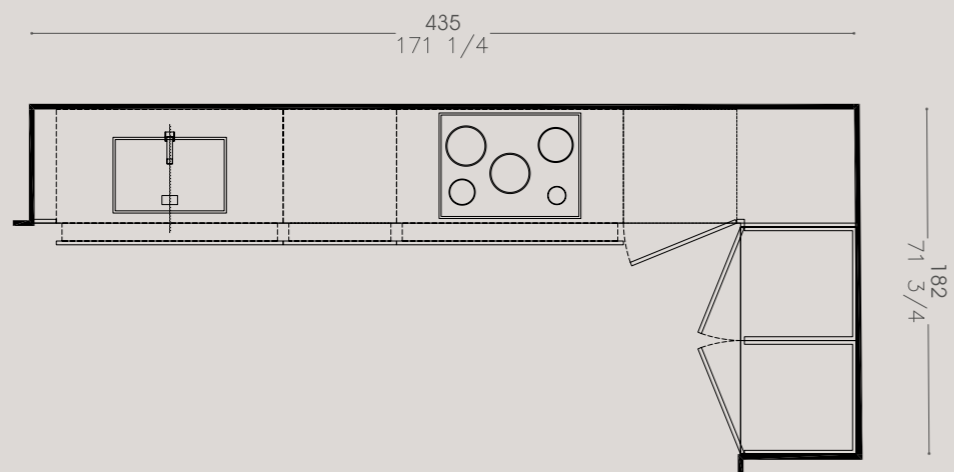

CAPITOLO 8

Colonne con anta a battente con maniglia metallica | bianco laccato lucido | metallo champagne lucido | vano interno frigorifero |

Basi 120/60 con 2 cassetti | bianco laccato lucido | **Pensili 60** con anta battente | vetrite calacatta natural | **Top e backsplash** in vetrite calacatta natural

CHAPTER 8

Columns with hinged door with metal handle | polished white lacquered | champagne polished metal | internal refrigerator compartment |

Bases 120/60 with 2 drawers | polished white lacquered | **Wall units 60** with hinged door | calacatta natural vetrite | **Top and backsplash** in calacatta natural vetrite





- 01** collezione mosaico cosmati | marmo statuario lucido
cosmati mosaic collection | polished statuario marble
- 02** laccato bianco lucido
white polished lacquered
- 03** vetro con rete
glass with mesh
- 03** metallo champagne lucido
champagne polished metal
- 05** vetrite calacatta natural
calacatta natural vetrite



Dettaglio del backsplash in Vetrite calacatta natural retroilluminato
Detail of the backsplash in backlit calacatta natural backlit Vetrite





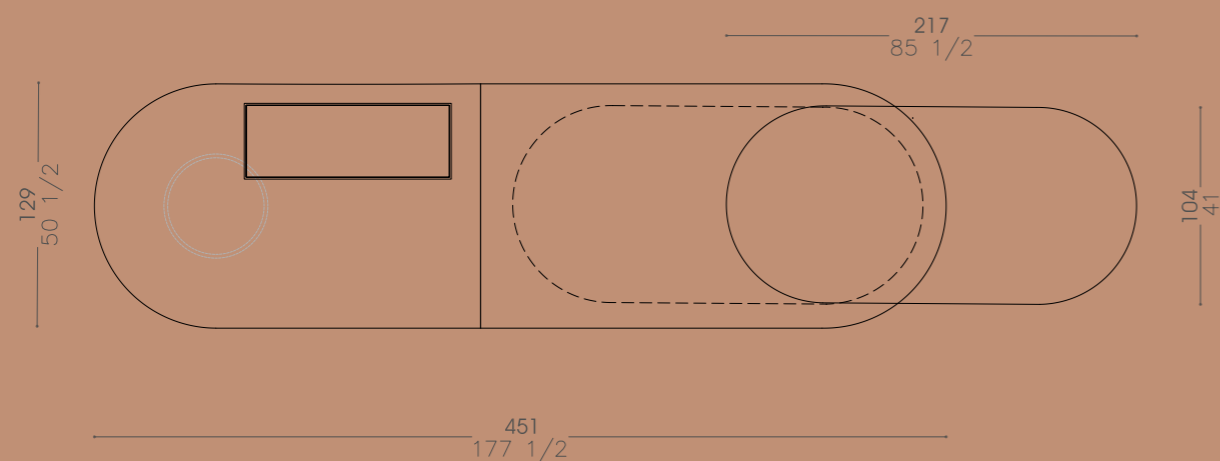
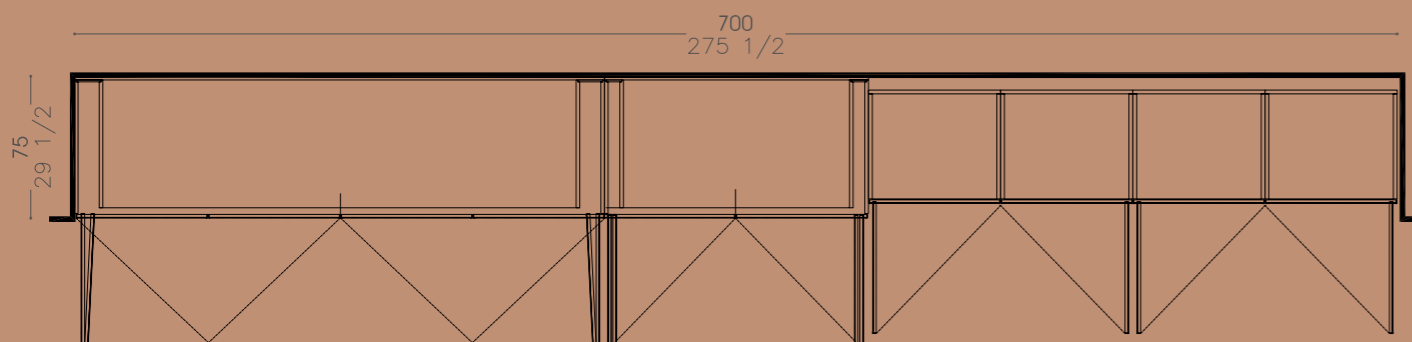

CAPITOLO 9

Colonne con anta a scomparsa cannettata wave con cornice metallica | essenza ebano ammara opaco | metallo champagne lucido | vetrite onigem honey | modulo quadruplo con interno ante battente e pensili in metallo | modulo doppio con interno modulo forno e cantina vini |

Basi 60 con ante a battente | essenza ebano ammara opaco |

Isola centrale RI.PC.03 SX con piano cottura a induzione + RI.PCM.03 DX con tavolo ovale 217cm |

Schienale in mosaico artistico

CHAPTER 9

Columns with retractable ribbed wave door with metal frame | matte ammara ebony wood | champagne polished metal | onigem honey vetrite | quadruple module with internal hinged doors and metal wall units | double module with internal oven and wine cellar |

Bases 60 with with hinged doors | matte ammara ebony wood | champagne polished metal |

Central island RI.PC.03 SX with induction cooktop + RI.PCM.03 DX with oval table 217cm |

Cupboard back artistic mosaic













01



02

03

04



- 01** cannettato wave | essenza ebano ammara opaco
ribbed wave | matte ammara ebony wood
- 02** metallo champagne lucido
champagne polished metal
- 03** vetro con rete
glass with mesh
- 04** vetrite onigem honey
onigem honey vetrite



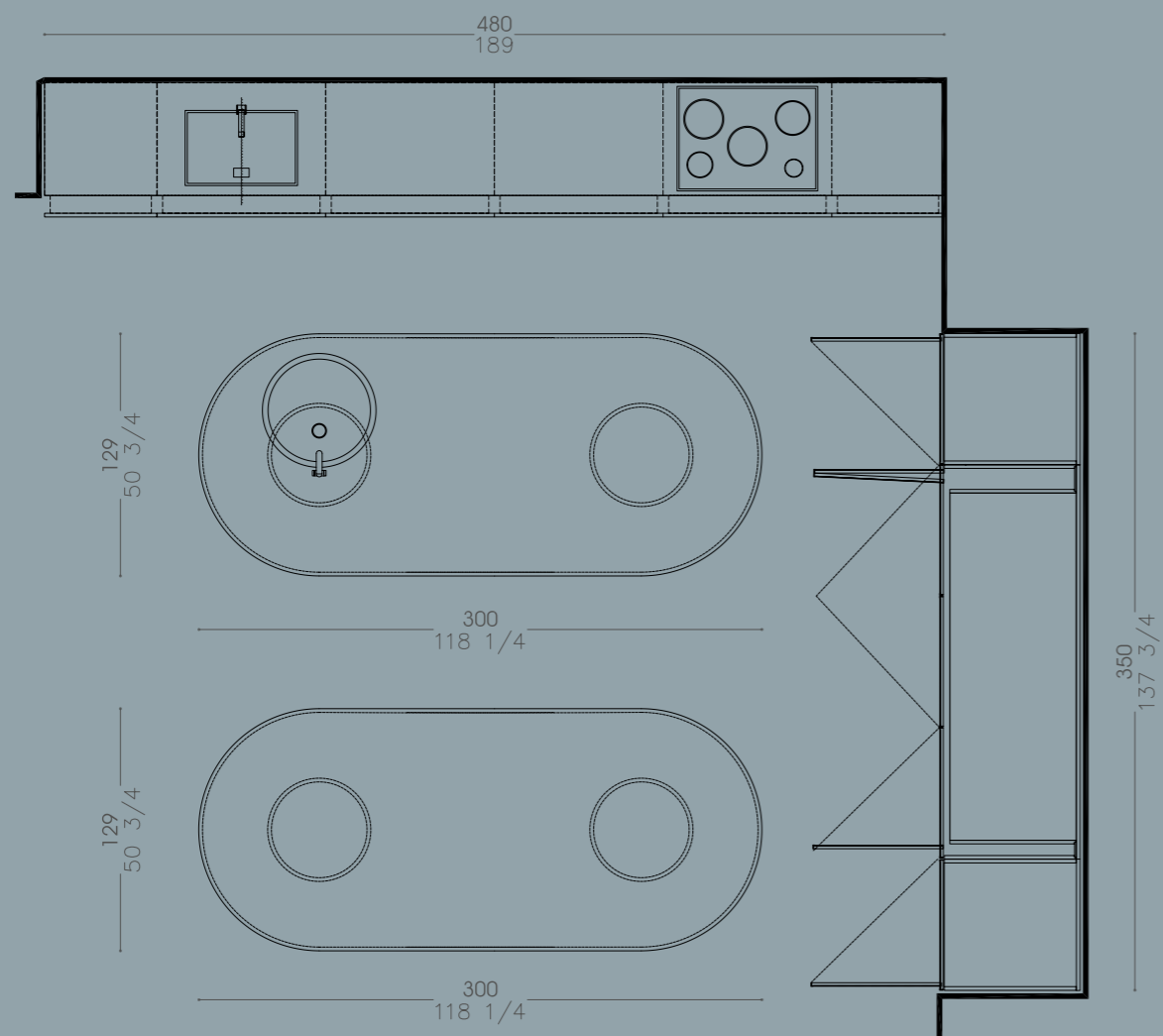

CAPITOLO 10

Colonne con anta a scomparsa in vetro con rete e profilo metallico | essenza rovere grigio opaco | metallo nichel nero lucido | modulo triplo con interno ante battente e mensole | schienale vetrite calacatta natural con retroilluminazione | 2 modulo singolo frigorifero e congelatore | laccatura lucida petrolio |

Basi 90/60 con 2 cassetti | laccatura lucida petrolio | metallo nichel nero lucido |

Pensili 60 con anta battente | essenza rovere grigio opaco |

Isola centrale RI.ISC.02 con lavello rotondo diametro 55 cm |

Isola centrale RI.ISC.01 |

Top e backsplash in vetrite calacatta natural

CHAPTER 10

Columns with glass retractable door with mesh and metal profile | matte gray oak wood | black nickel polished metal | triple module with internal hinged doors and shelves | cupboard back in calacatta natural vetrite with backlighting | 2 single module refrigerator and freezer | petroleum polished lacquer |

Bases 90/60 with 2 drawers | petroleum polished lacquer | black nickel polished metal |

Wall unit 60 with hinged door | matte grey oak wood |

Central island RI.ISC.02 with round sink diameter 55 cm |

Central island RI.ISC.01 |

Top and backsplash in calacatta natural vetrite







- 01** vetrite onigem bolt
onigem bolt vetrite
- 02** vetrite rock
rock vetrite
- 03** laccatura lucida petrolio
petroleum polished lacquer
- 04** cannettato wave | essenza rovere grigio opaco
ribbed wave | matte gray oak wood
- 05** metallo nichel nero lucido
black nickel polished metal
- 06** vetro con rete
glass with mesh
- 07** vetrite calacatta natural
calacatta natural vetrite





INFORMAZIONI TECNICHE
technical information

COLONNE A SCOMPARSA

retractable columns

ANTE 70 CM

doors 70 cm

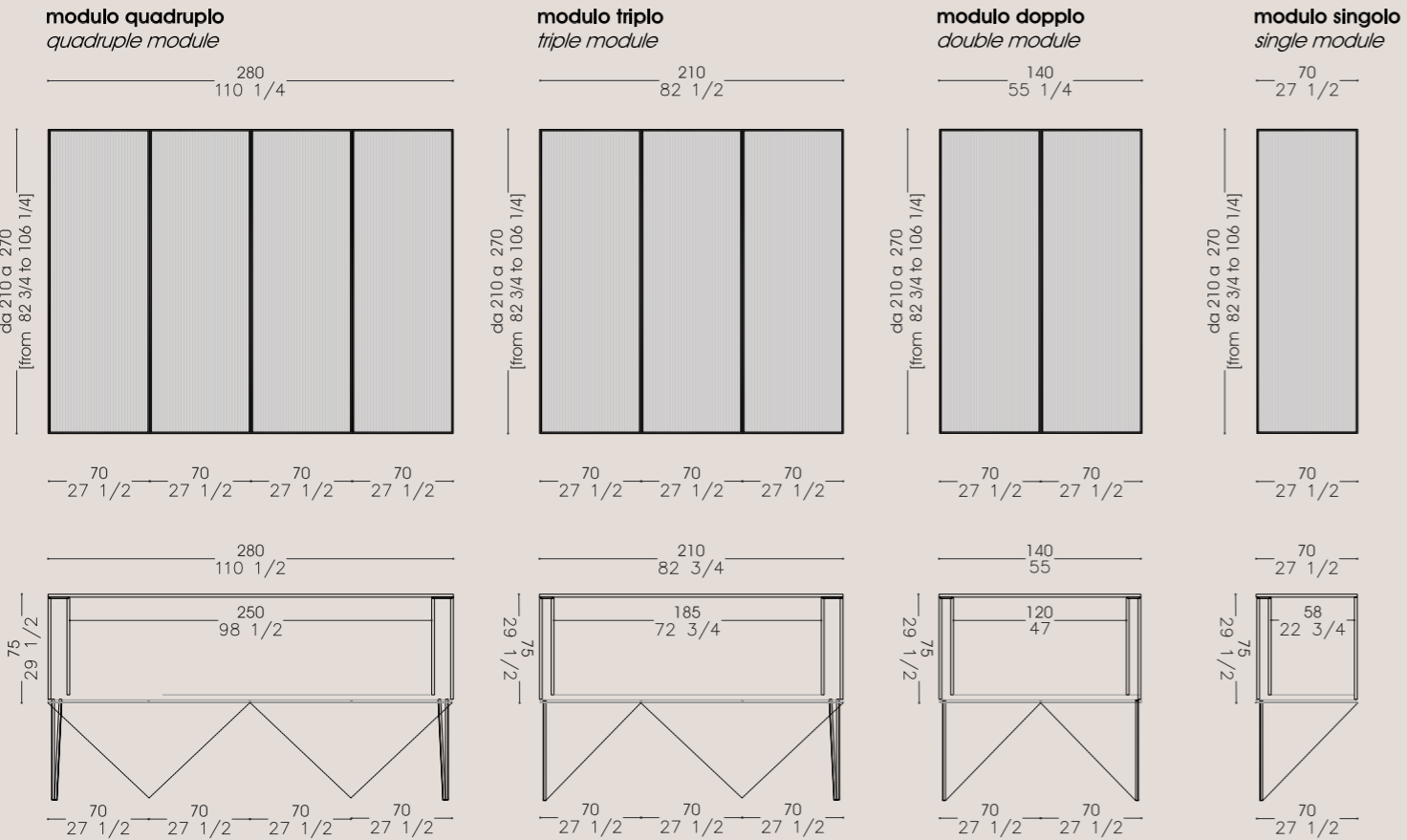

ANTE 60 CM

doors 60 cm

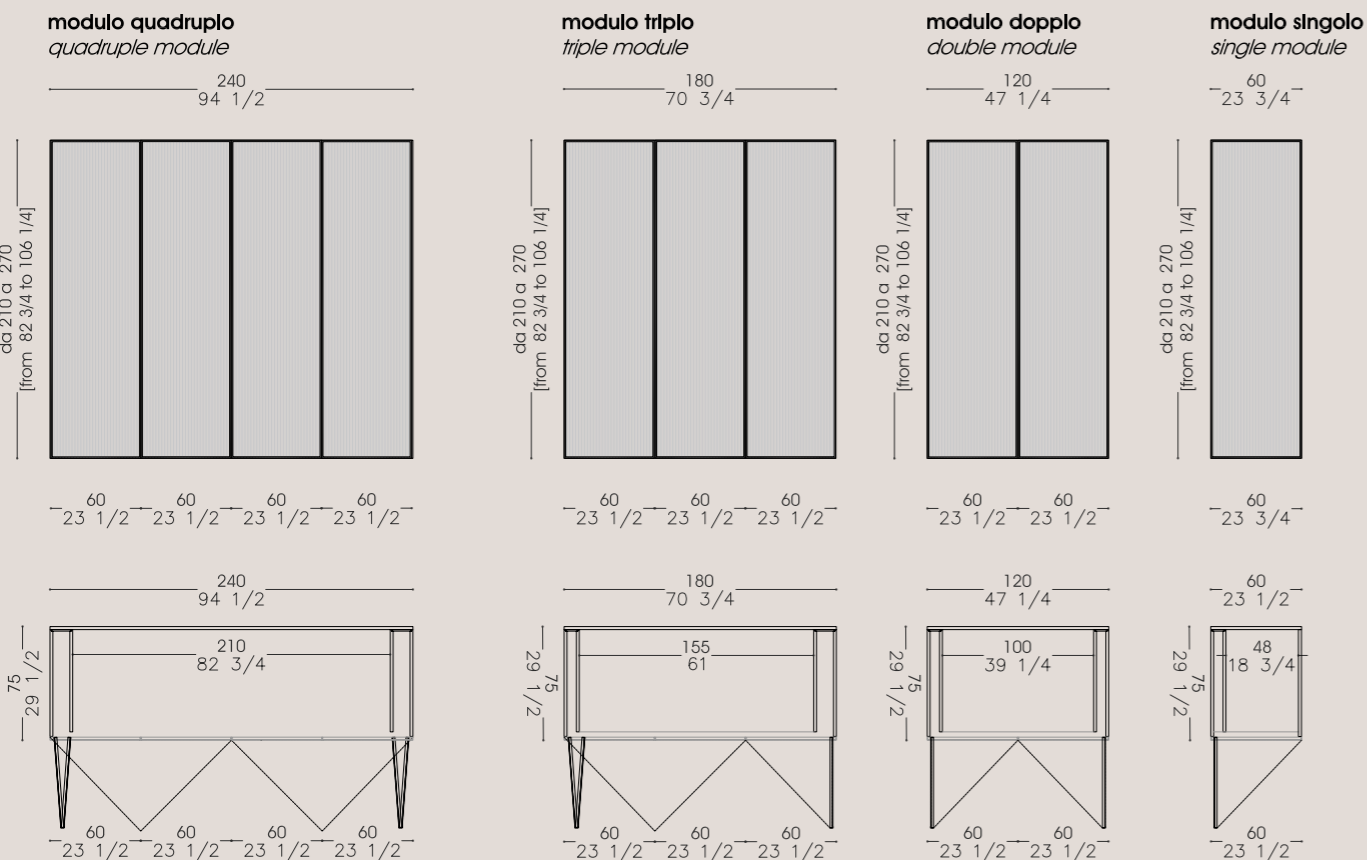

COLONNE ANTE BATTENTE

columns hinged doors

COLONNE CON ANTE BATTENTE | MODULI SINGOLI

columns with hinged doors | single module

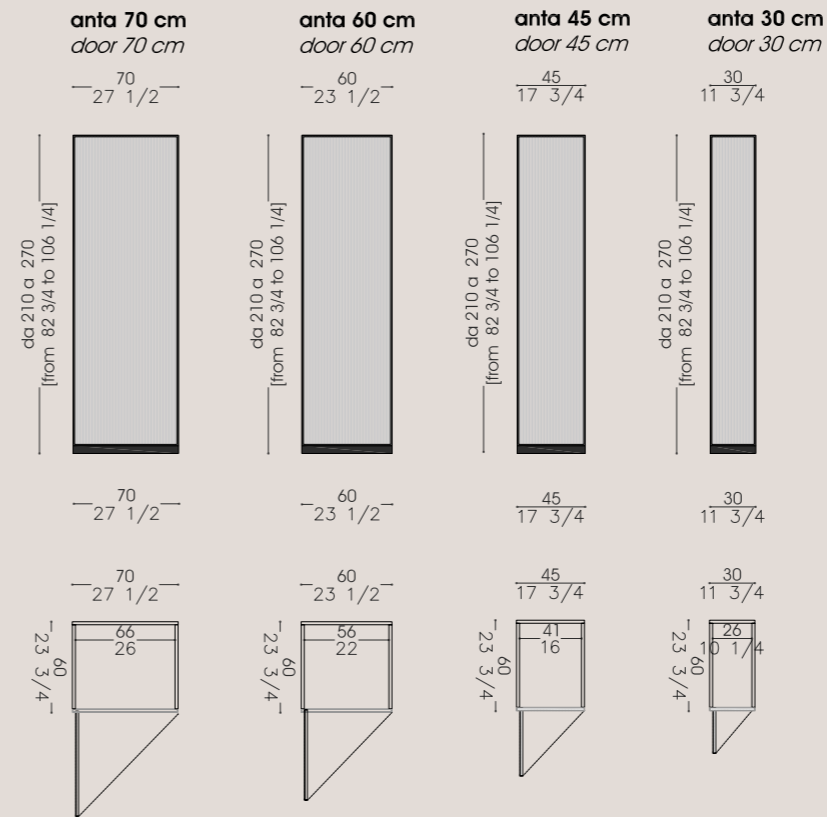

COLONNE CON ANTE BATTENTE | MODULI DOPPI

columns with hinged doors | double module

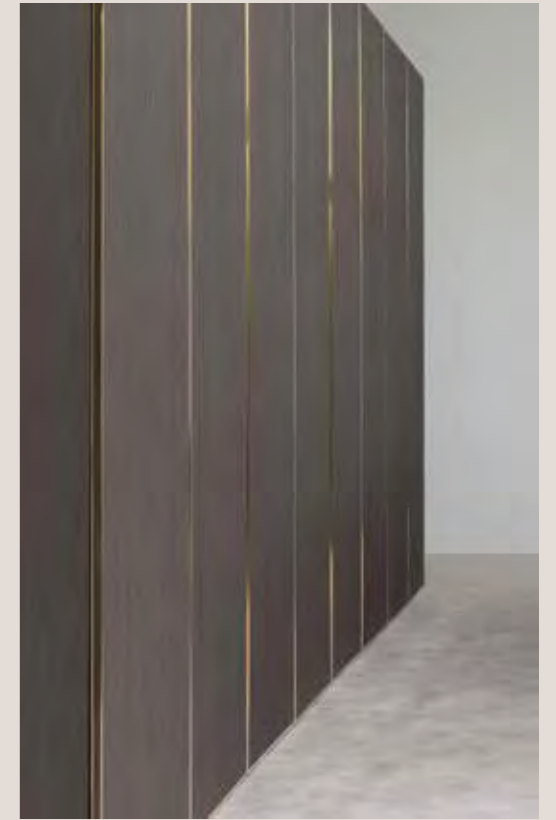
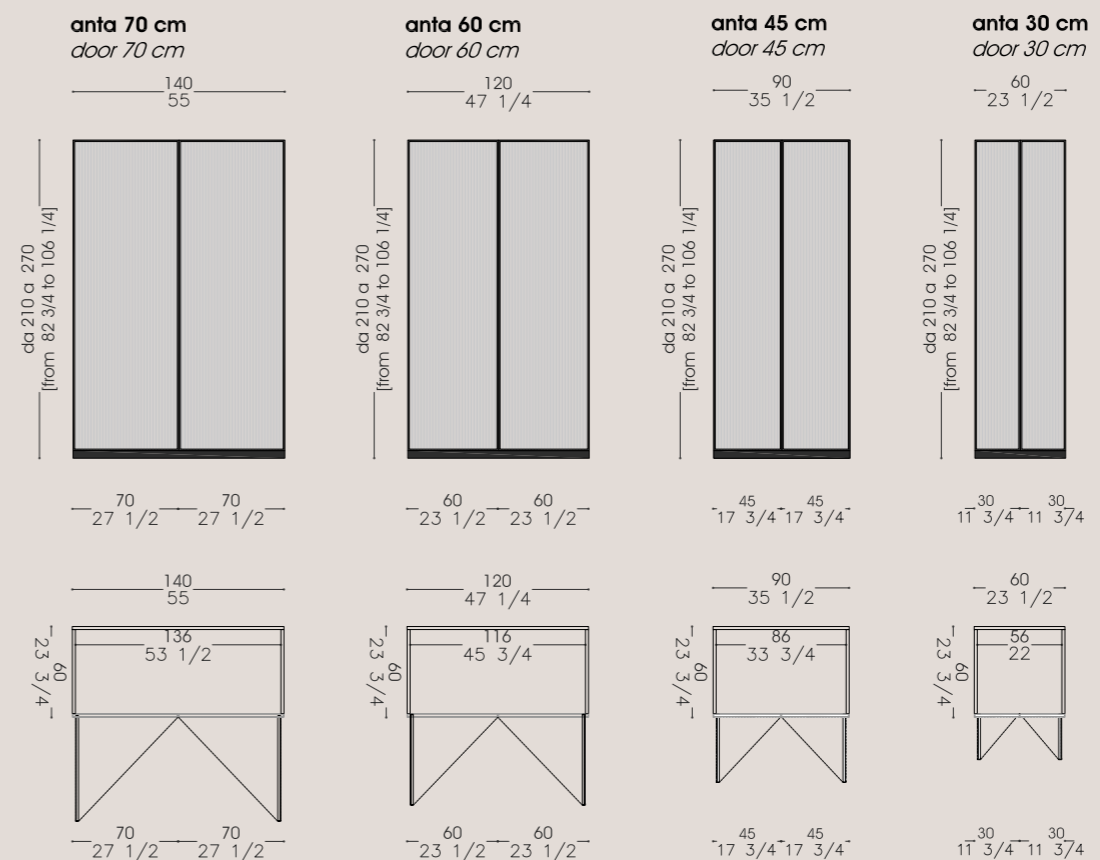

COLONNE A SCOMPARSA

retractable columns

COMBINAZIONI INTERNE

interiors combinations

modulo forno
oven module

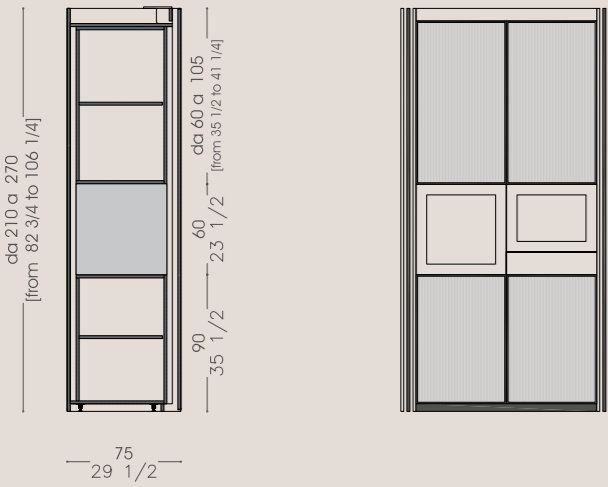

COLONNE A SCOMPARSA

retractable columns

COMBINAZIONI INTERNE

interiors combinations

modulo con cassetti e mensole
module with drawers and shelves

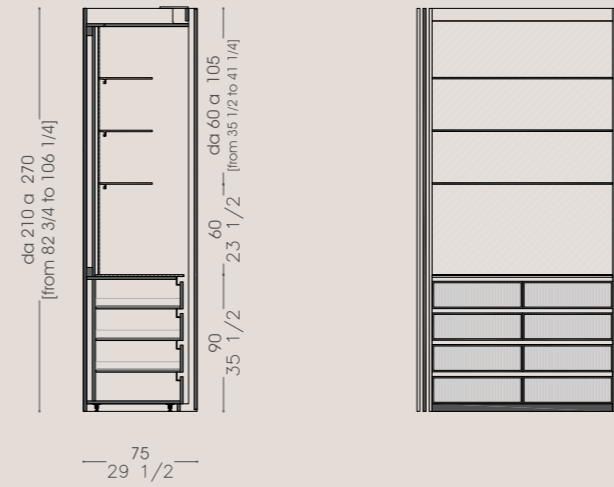

modulo con ante battente e mensole
module with hinged doors and shelves

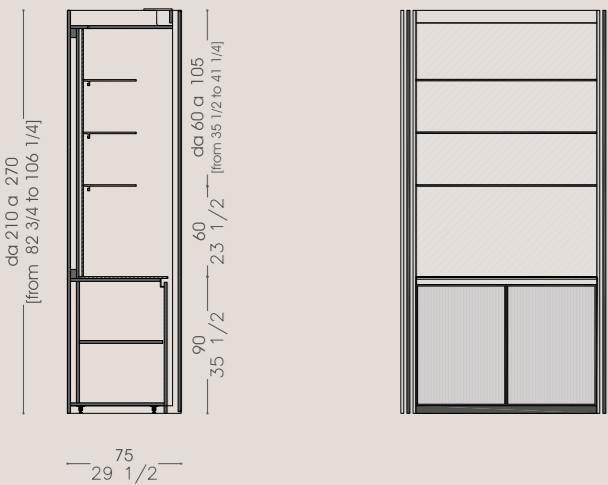

modulo con cassetti e pensili
module with drawers and wall units

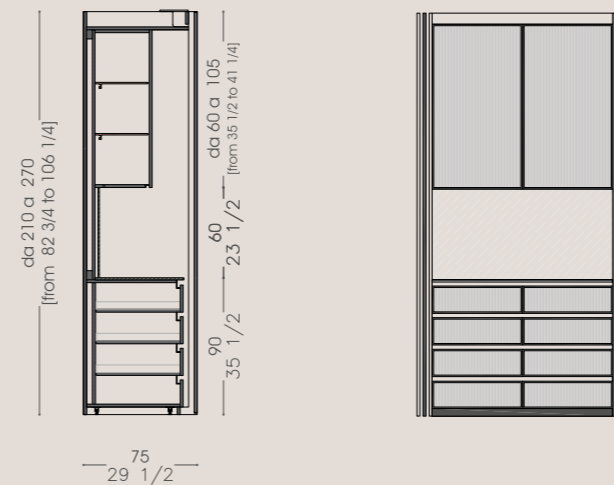

modulo con ante battente e pensili
module with hinged doors and wall units

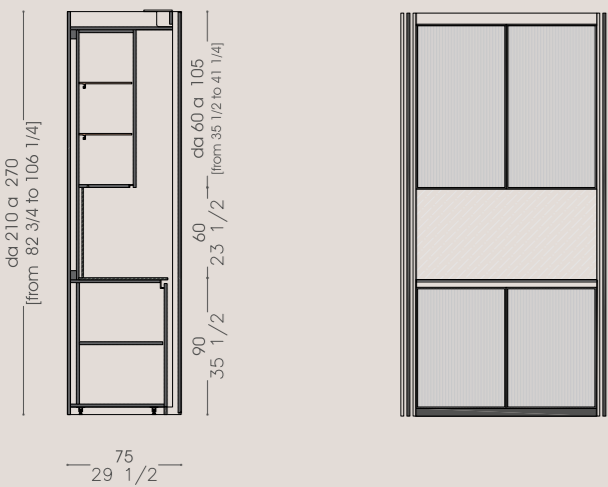

modulo con mensole
module with shelves

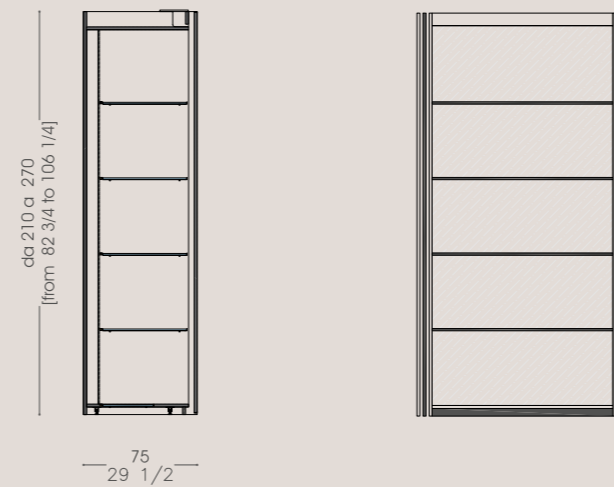

COLONNE
columns

COMBINAZIONI
combinations

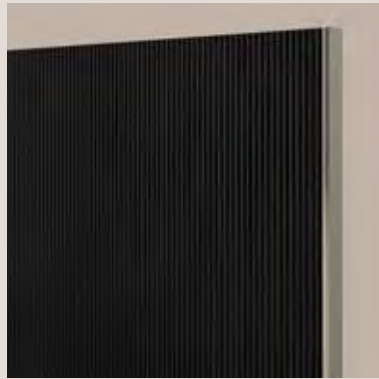

ANTa WAVE - LEGNO - MANIGLIA METALLICA
wave door - wood - metal handle

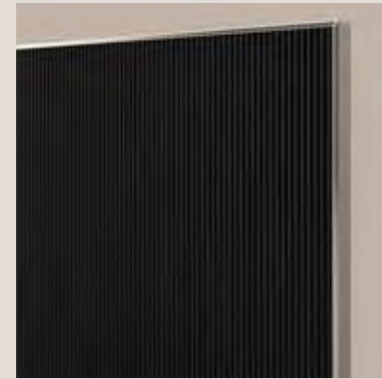

ANTa WAVE - LEGNO - CORNICE METALLICA
wave door - wood - metal frame

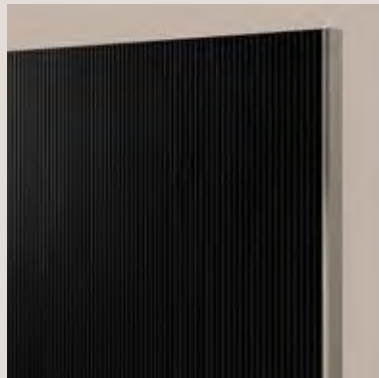

ANTa LINE - LEGNO - MANIGLIA METALLICA
line door - wood - metal handle

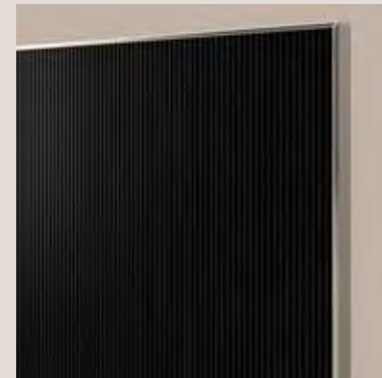

ANTa LINE - LEGNO - CORNICE METALLICA
line door - wood - metal frame



ANTa WAVE - LACCATA - MANIGLIA METALLICA
wave door - lacquered - metal handle



ANTa WAVE - LACCATA - CORNICE METALLICA
wave door - lacquered - metal frame

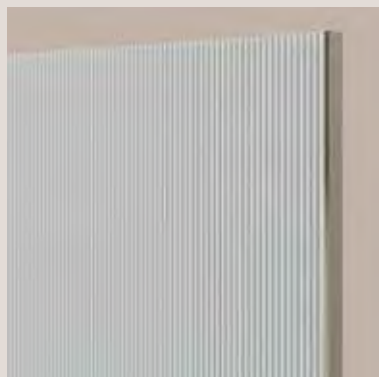

ANTa LINE - LACCATA - MANIGLIA METALLICA
line door - lacquered - metal handle

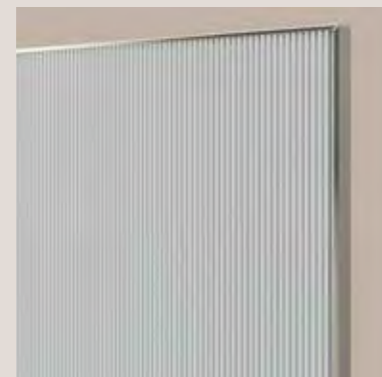

ANTa LINE - LACCATA - CORNICE METALLICA
line door - lacquered - metal frame

COLONNE
columns

COMBINAZIONI
combinations

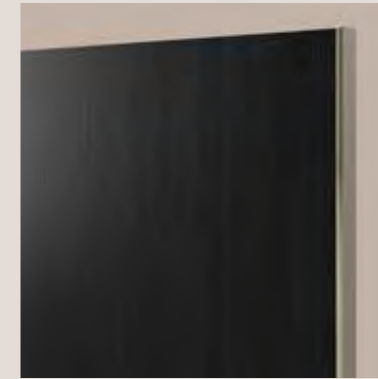

ANTa PLANE - LEGNO - MANIGLIA METALLICA
plane door - wood - metal handle

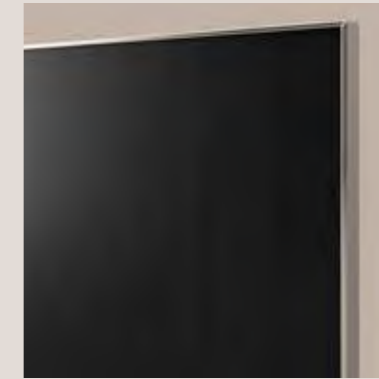

ANTa PLANE - LEGNO - CORNICE METALLICA
plane door - wood - metal frame



ANTa PLANE - LACCATA - MANIGLIA METALLICA
plane door - lacquered - metal handle

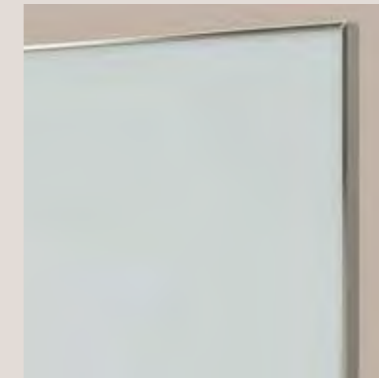

ANTa PLANE - LACCATA - CORNICE METALLICA
plane door - lacquered - metal frame



ANTa VETRO CON RETE - CORNICE METALLICA
glass door with mesh - metal handle

L'ANTa IN VETRO CON RETE È DISPONIBILE SOLO CON CORNICE METALLICA PERIMETRALE
The glass door with mesh is only available with a metal perimeter frame



ANTa VETRITE - CORNICE METALLICA
vetrite door - metal frame

L'ANTa IN VETRITE È DISPONIBILE SOLO CON CORNICE METALLICA PERIMETRALE
vetrite door is only available with a metal perimeter frame

BASI ANTA BATTENTE

bases hinged door

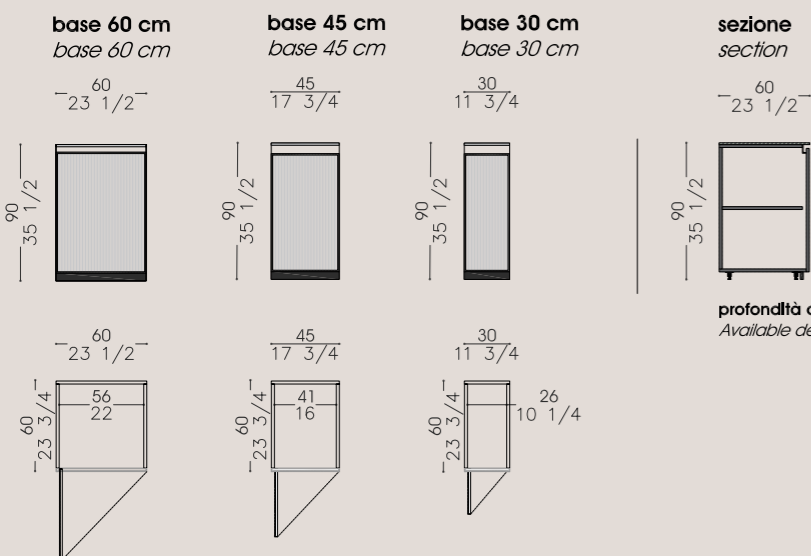

BASI CON 3 CASSETTI

bases with 3 drawers

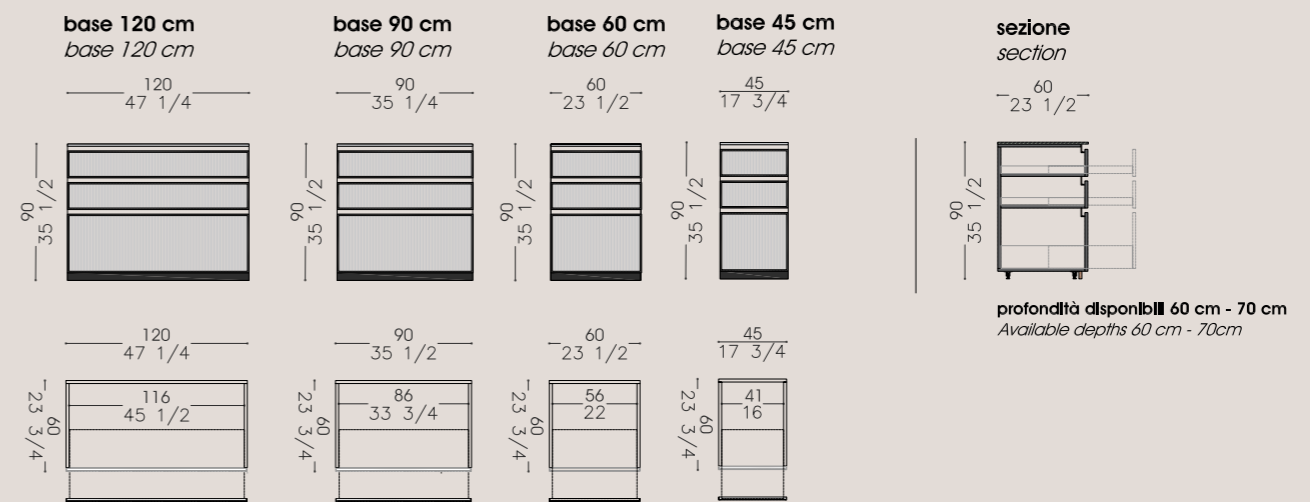

BASI CON 1 CASSETTO ESTERNO + 1 INTERNO

bases with 1 external drawer + 1 internal

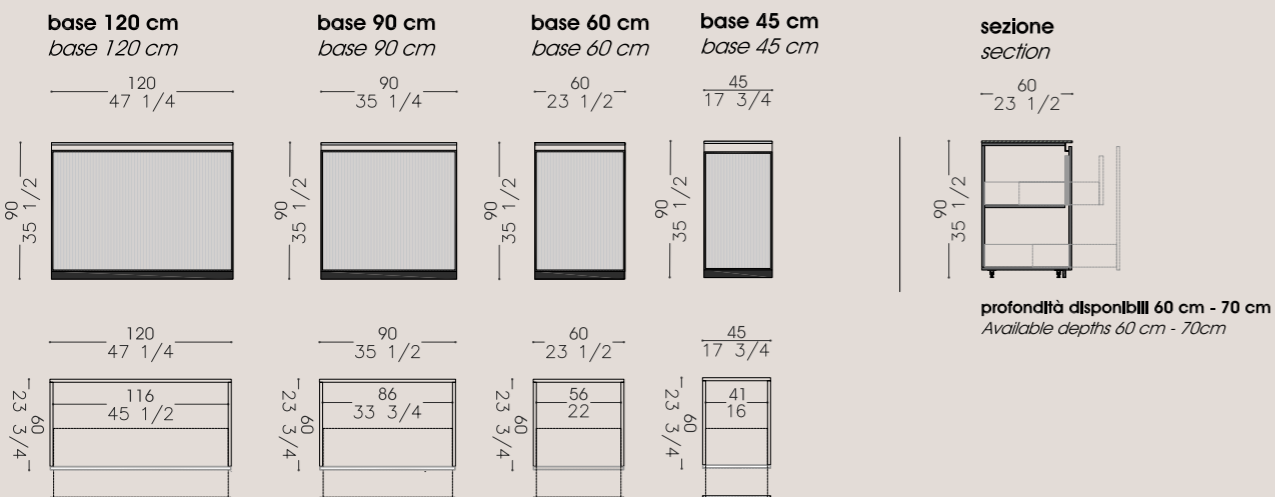

BASI CON 3 CASSETTI

bases with 3 drawers

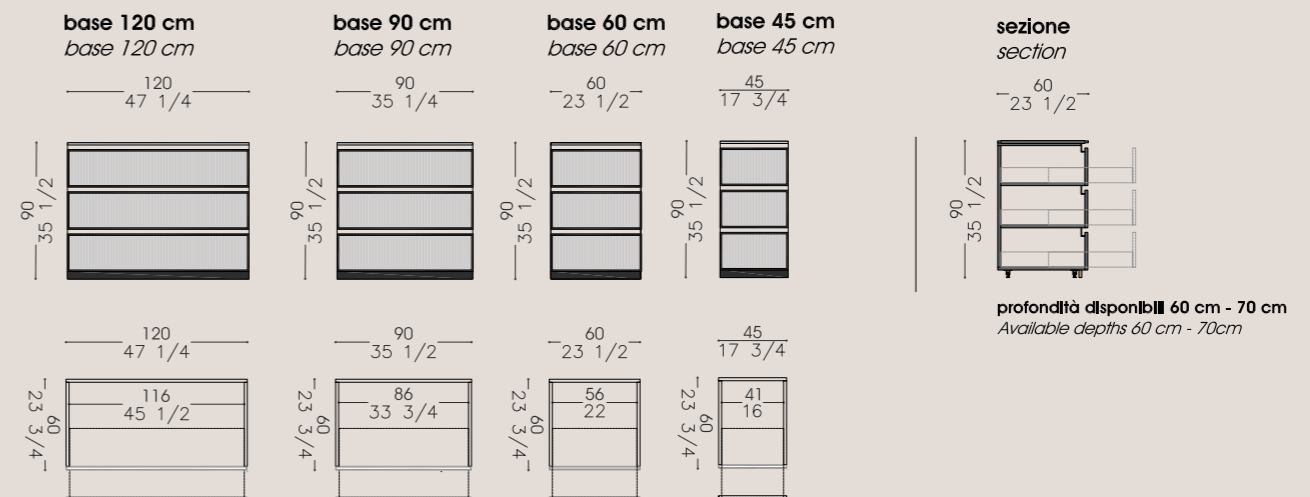

BASI CON 2 CASSETTI

bases with 2 drawers

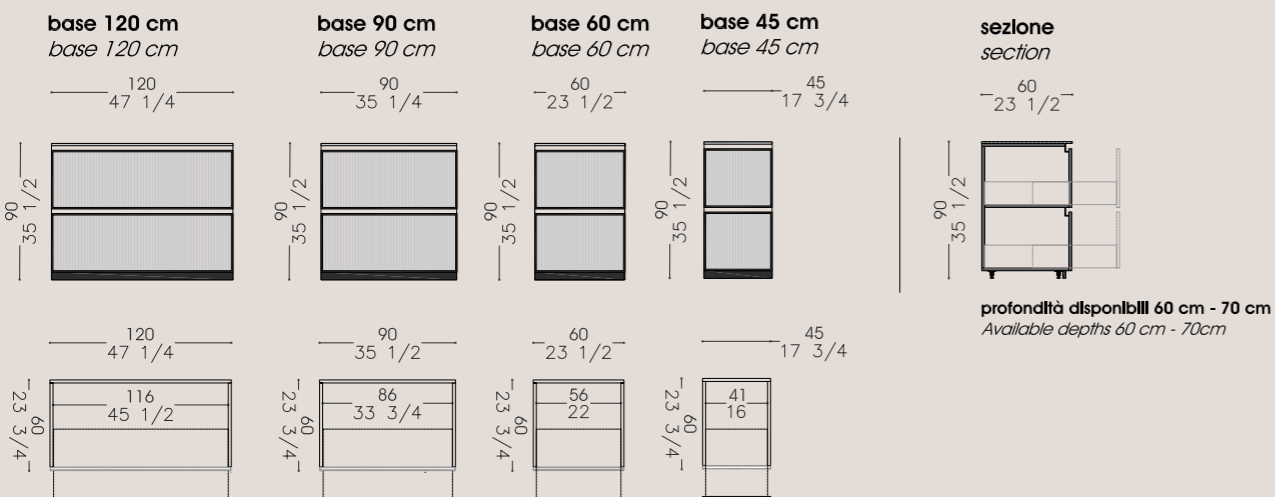

BASI CON 4 CASSETTI

bases with 4 drawers

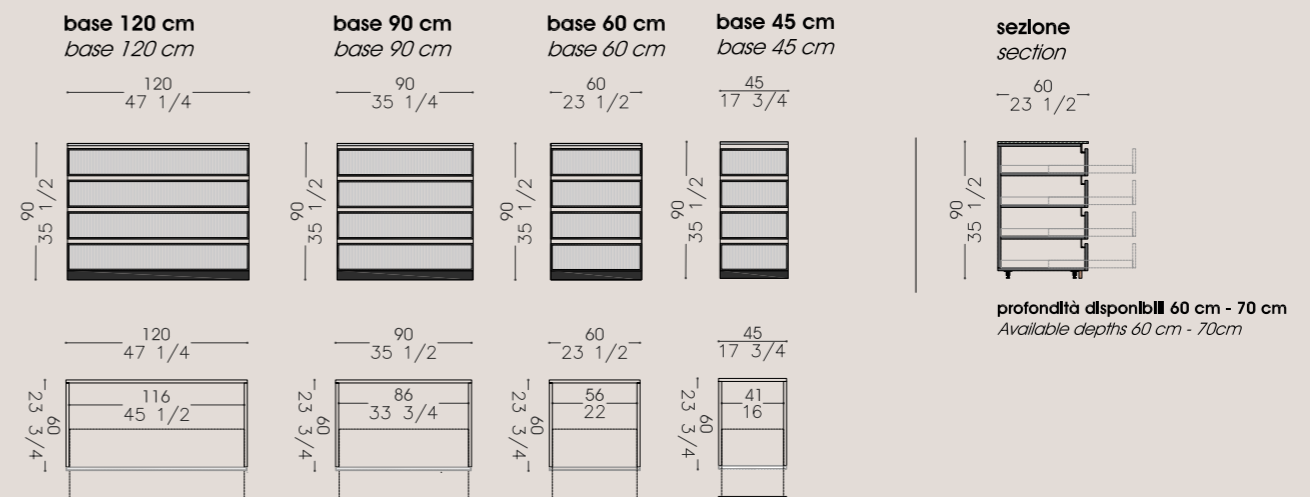

PENSILI

wall units

PENSILI CON ANTE BATTENTE

wall units with hinged doors

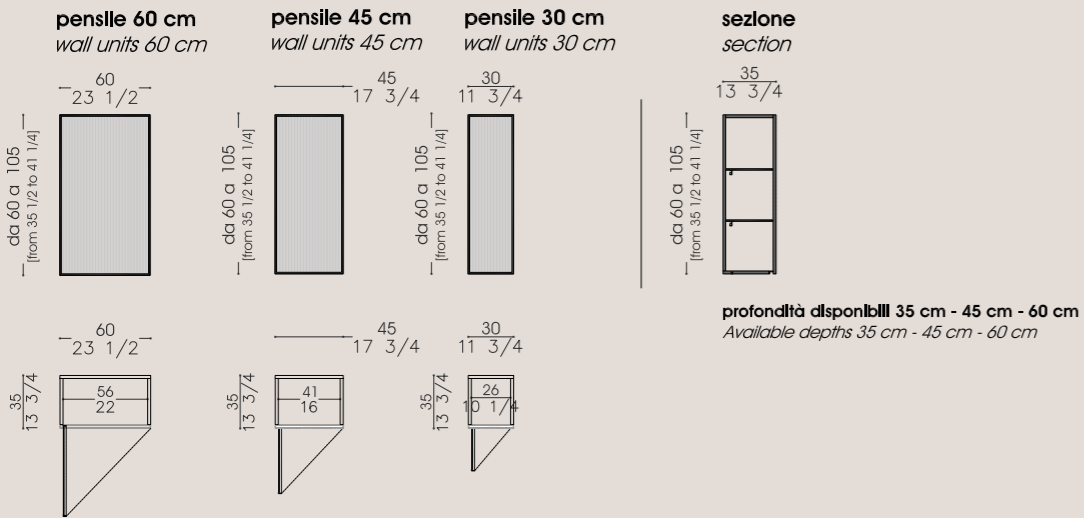

PENSILI CON ANTE BATTENTE | MODULI DOPPI

wall units with hinged doors / double module

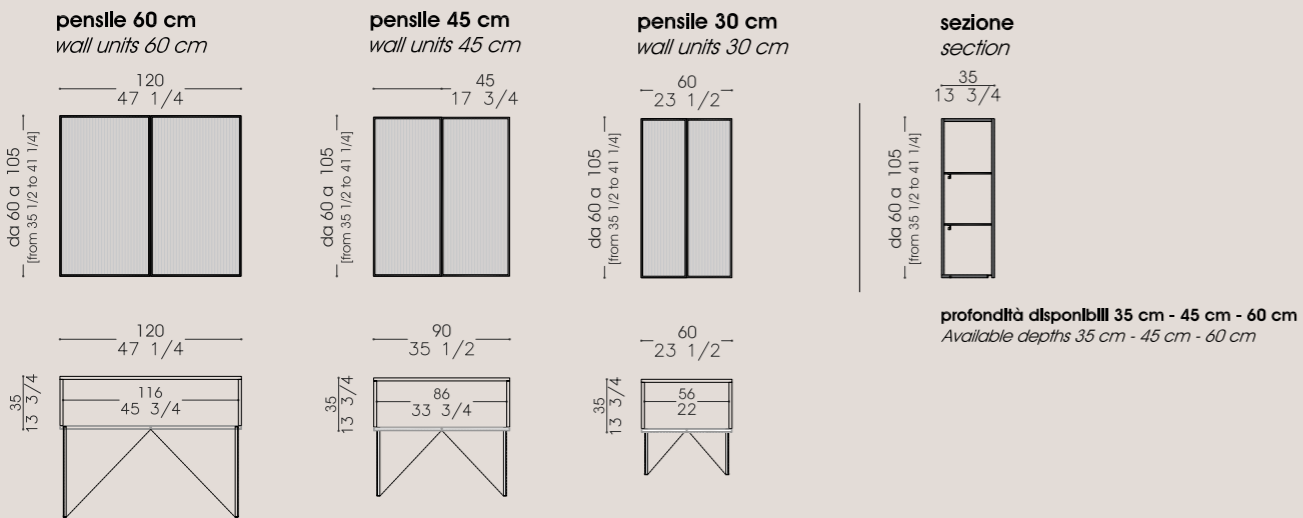

PENSILI CON ANTE RIBALTA

wall units with flap opening

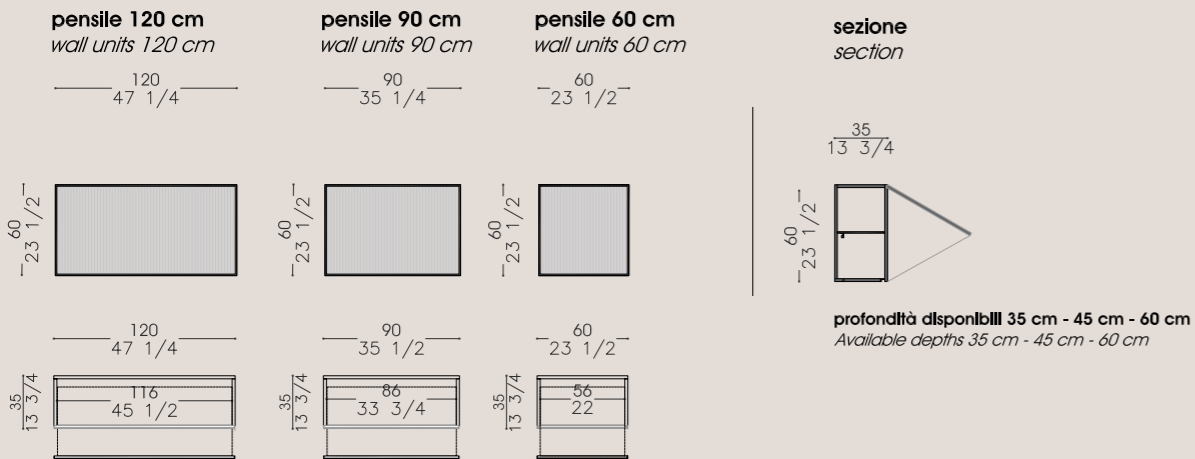

ANTE PENSILI E BASI
doors for wall units and bases

COMBINAZIONI
combinations



ANTA PLANE - LEGNO
plane door - wood

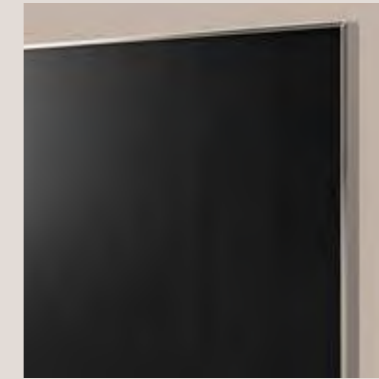

ANTA PLANE - LEGNO - CORNICE METALLICA
plane door - wood - metal frame



ANTA PLANE - LACCATA
plane door - lacquered



ANTA PLANE - LACCATA - CORNICE METALLICA
plane door - lacquered - metal frame

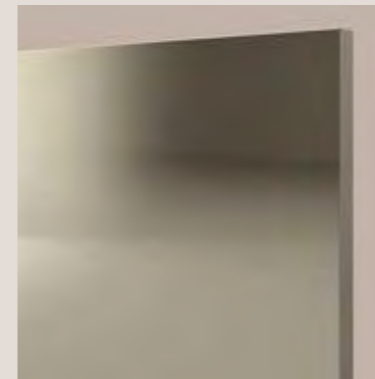

ANTA METALLO
metal door



ANTA VETRO CON RETE - CORNICE METALLICA
glass door with mesh - metal handle

L'ANTA IN VETRO CON RETE È DISPONIBILE SOLO CON CORNICE METALLICA PERIMETRALE ED
The glass door with mesh is only available with a metal perimeter frame



ANTA VETRITE
vetrite door



ANTA VETRITE - CORNICE METALLICA
vetrite door - metal frame



ISOLA CURVA

round island

RI.PC.01 DX - SX

penisola curva | piede rotondo | 1 fila di cassetti
curved peninsula | round foot | 1 row of drawers

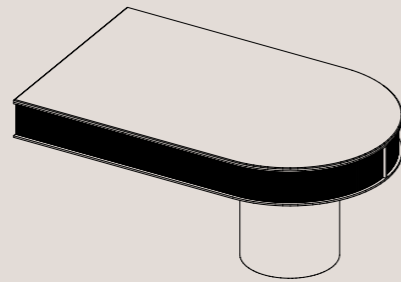
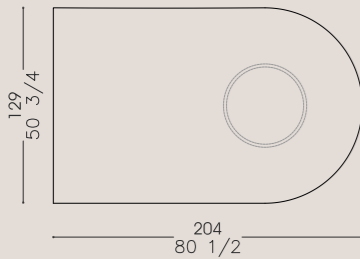

RI.PC.02 DX - SX

penisola curva | piede rotondo | 1 fila di cassetti | lavabo rotondo
curved peninsula | round foot | 1 row of drawers | round sink

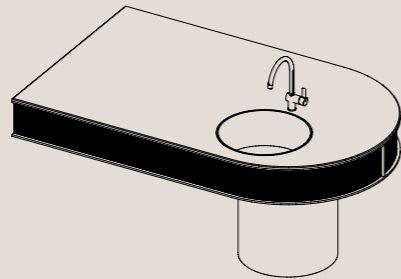
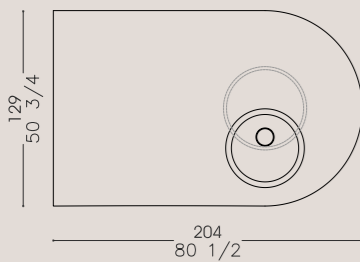

RI.PC.03 DX - SX

penisola curva | piede rotondo | 1 fila di cassetti | piano cottura
curved peninsula | round foot | 1 row of drawers | cooktop

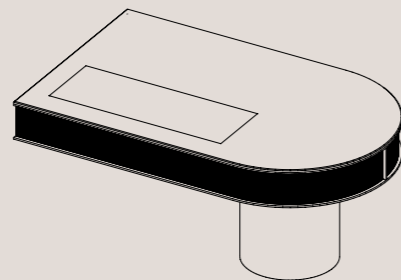
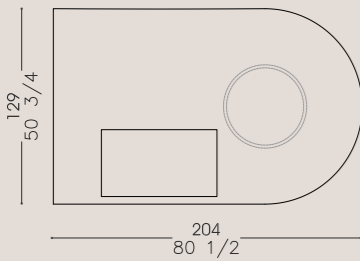

RI.PC.04 DX - SX

penisola curva | piede rotondo | 2 fila di cassetti
curved peninsula | round foot | 2 rows of drawers

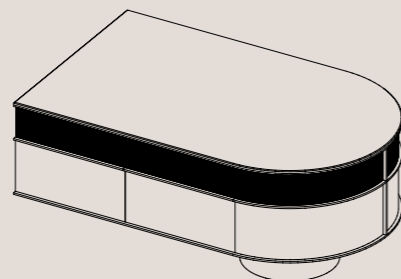
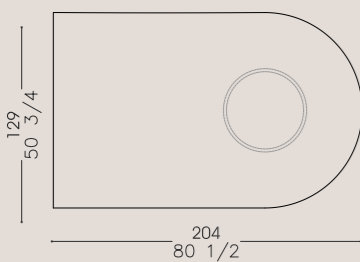

RI.PC.05 DX - SX

penisola curva | piede rotondo | 2 fila di cassetti | lavabo rotondo
curved peninsula | round foot | 2 rows of drawers | round sink

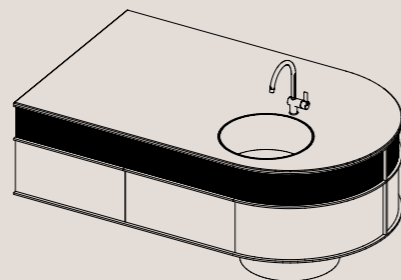
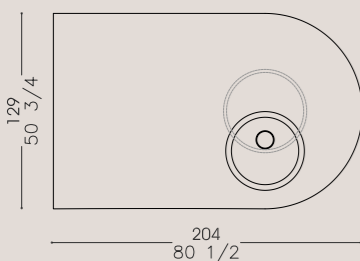

RI.PC.06 DX - SX

penisola curva | piede rotondo | 2 fila di cassetti | piano cottura
curved peninsula | round foot | 2 rows of drawers | cooktop

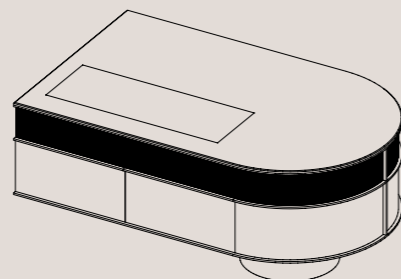
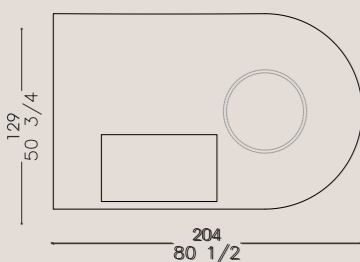

ISOLA QUADRATA

square island

RI.PR.01 DX - SX

penisola rettilinea | piede rotondo | 1 fila di cassetti
straight peninsula | round foot | 1 row of drawers

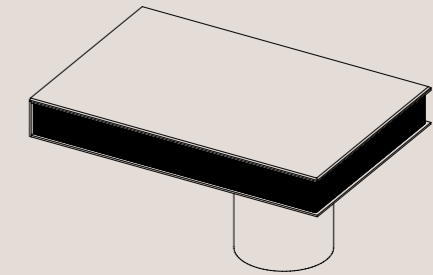
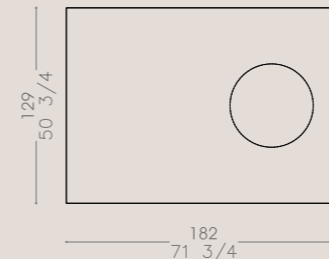

RI.PR.02 DX - SX

penisola rettilinea | piede rotondo | 1 fila di cassetti | lavabo rotondo
straight peninsula | round foot | 1 row of drawers | round sink

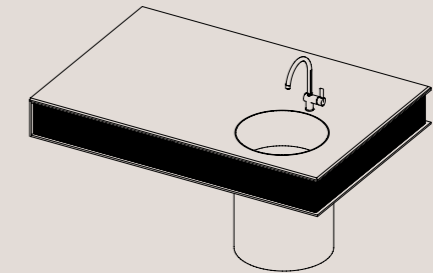
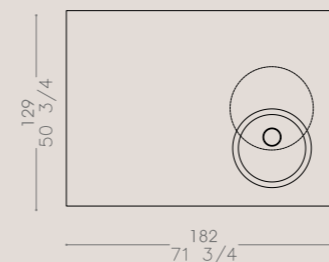

RI.PR.03 DX - SX

penisola rettilinea | piede rotondo | 1 fila di cassetti | piano cottura
straight peninsula | round foot | 1 row of drawers | cooktop

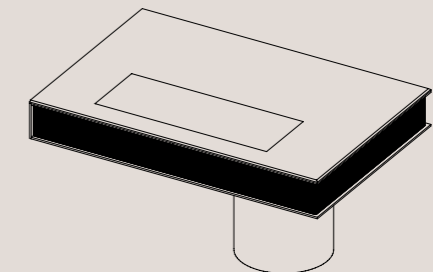
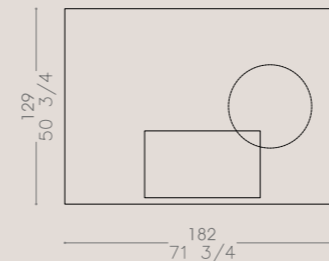

RI.PR.04 DX - SX

penisola rettilinea | piede rotondo | 2 fila di cassetti
straight peninsula | round foot | 2 rows of drawers

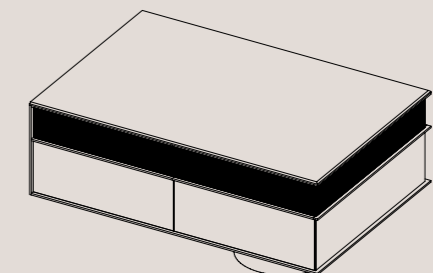
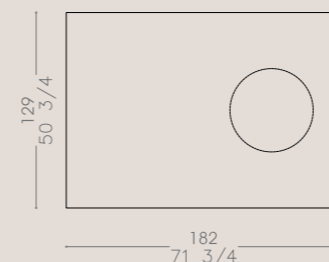

RI.PR.05 DX - SX

penisola rettilinea | piede rotondo | 2 fila di cassetti | lavabo rotondo
straight peninsula | round foot | 2 rows of drawers | round sink

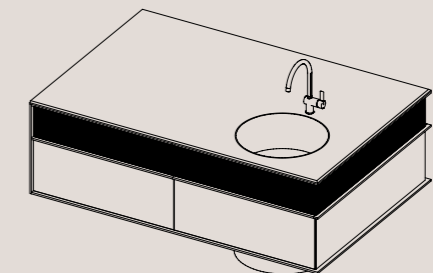
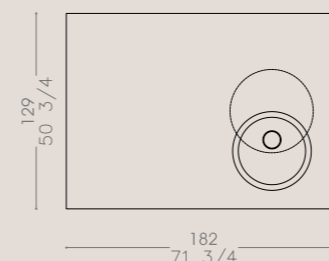

RI.PR.06 DX - SX

penisola rettilinea | piede rotondo | 2 fila di cassetti | piano cottura
straight peninsula | round foot | 2 rows of drawers | cooktop

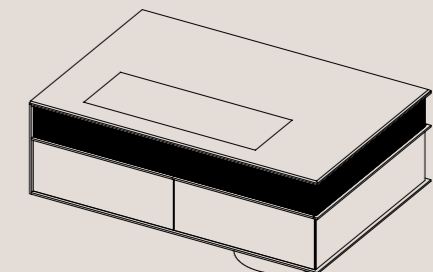
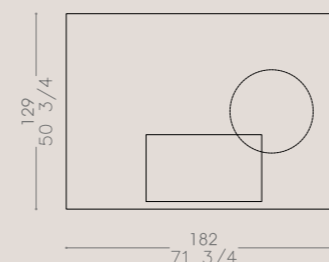

ISOLA CURVA

round island

RI.PCM.01 DX - SX

penisola curva | piedi lamina | 1 fila di cassetti
curved peninsula | blade feet | 1 row of drawers

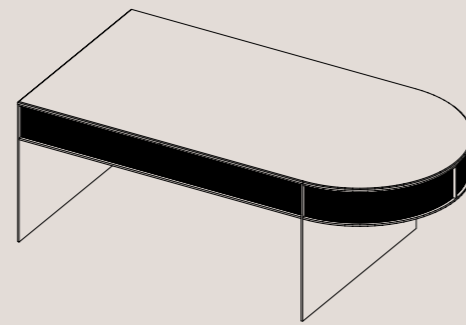
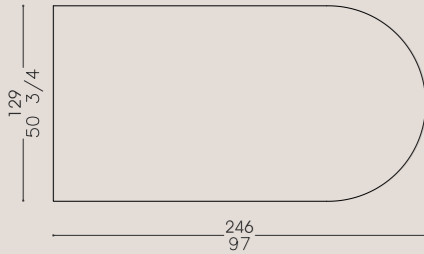

RI.PCM.02 DX - SX

penisola curva | piedi lamina | 1 fila di cassetti - piano cottura
curved peninsula | blade feet | 1 row of drawers - cooktop

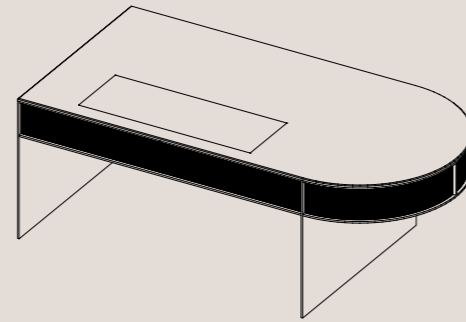
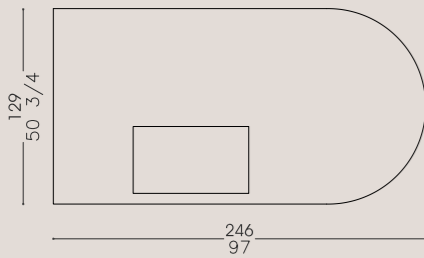

RI.PCM.03 DX - SX

penisola curva | piedi lamina | 2 fila di cassetti
curved peninsula | blade feet | 2 rows of drawers

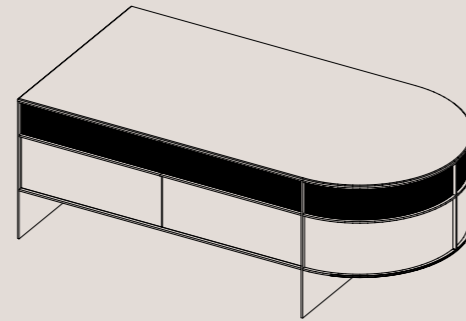
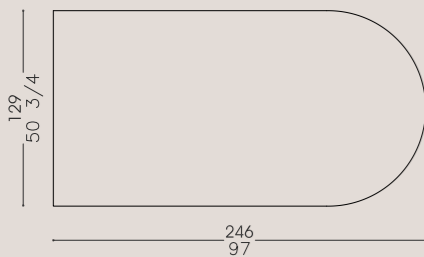

RI.PCM.04 DX - SX

penisola curva | piedi lamina | 2 fila di cassetti | piano cottura
curved peninsula | blade feet | 2 rows of drawers | cooktop

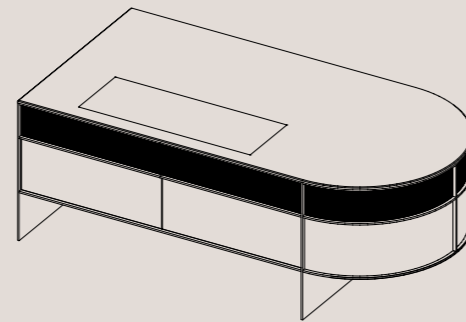
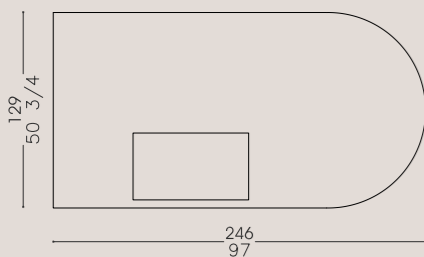

RI.ISC.01

isola rotonda | piedi rotondi | 1 fila di cassetti
round insula | round feet | 1 row of drawers

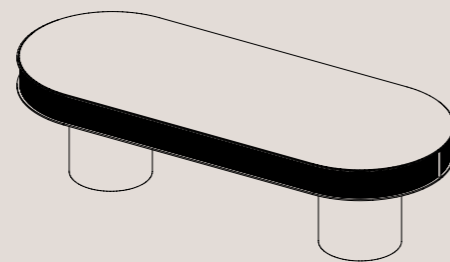
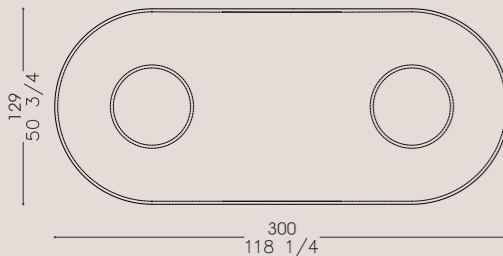

RI.ISC.02

isola rotonda | piedi rotondi | 2 fila di cassetti
round insula | round feet | 2 rows of drawers

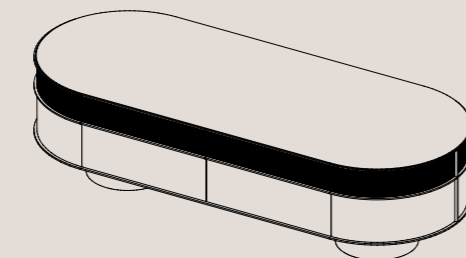
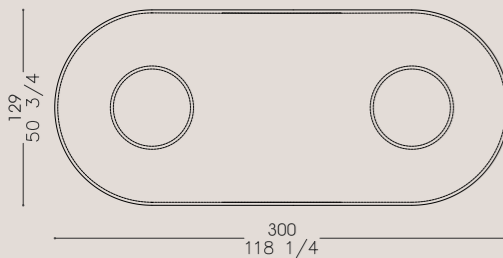

LE ISOLE COMPLETE SONO DISPONIBILI CON LAVELLO E PIANO COTTURA
the complete islands are available with sink and cooktop

ISOLA QUADRATA

square island

RI.ECM.01 DX - SX

penisola rettilinea | piedi lamina | 1 fila di cassetti
straight peninsula | blade feet | 1 row of drawers

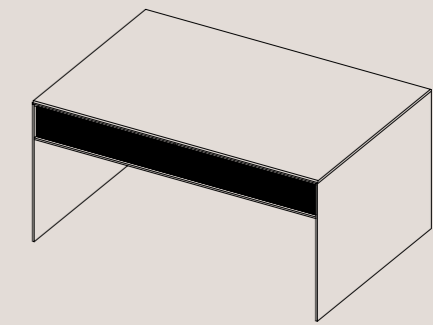
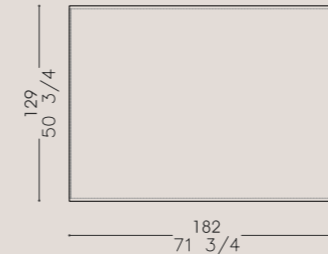

RI.ECM.02 DX - SX

penisola rettilinea | piedi lamina | 1 fila di cassetti | piano cottura
straight peninsula | blade feet | 1 row of drawers | cooktop

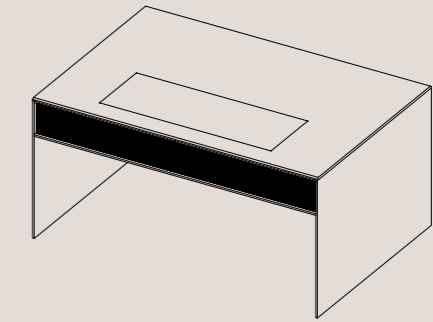
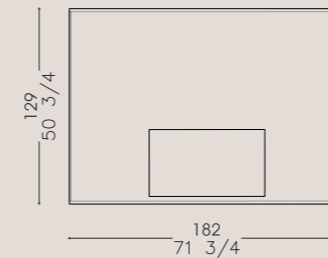

RI.ECM.03 DX - SX

penisola rettilinea | piedi lamina | 2 fila di cassetti
straight peninsula | blade feet | 2 rows of drawers

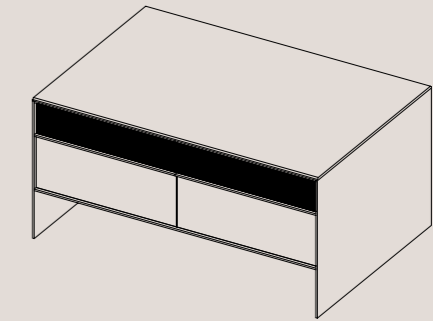
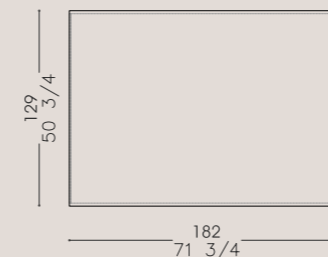

RI.ECM.04 DX - SX

penisola rettilinea | piedi lamina | 2 fila di cassetti | piano cottura
straight peninsula | blade feet | 2 rows of drawers | cooktop

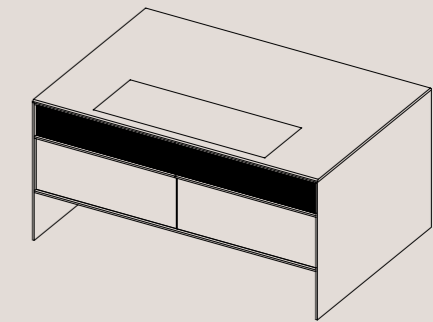
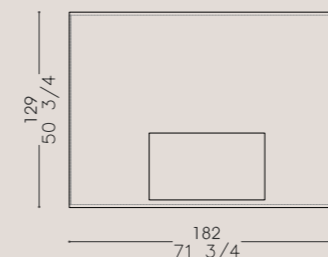

RI.ISR.01

isola rettangolare | piedi rotondi | 1 fila di cassetti
rectangular insula | round feet | 1 row of drawers

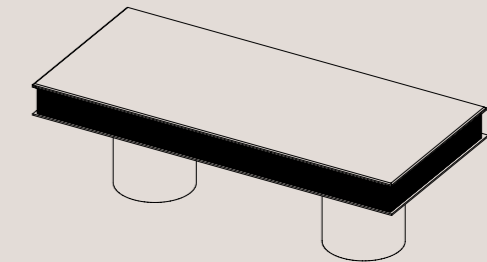
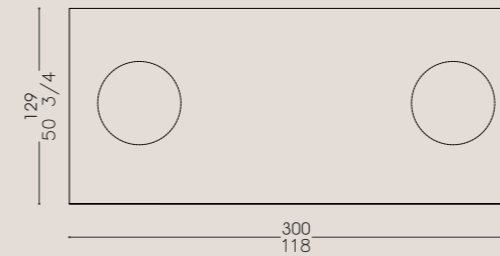

RI.ISR.02

isola rettangolare | piedi rotondi | 2 fila di cassetti
rectangular insula | round feet | 2 rows of drawers

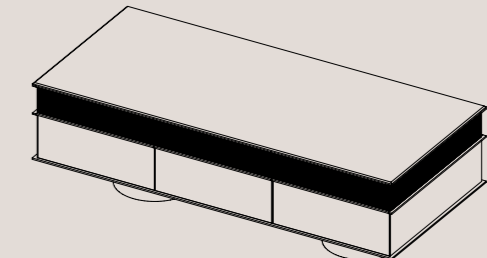
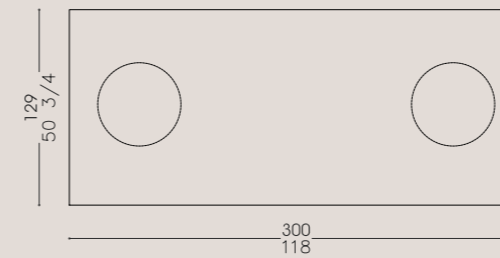

LE ISOLE COMPLETE SONO DISPONIBILI CON LAVELLO E PIANO COTTURA
the complete islands are available with sink and cooktop

VETRINA SOPESA

wall cabinet

VETRINA GRANDE

big cabinet

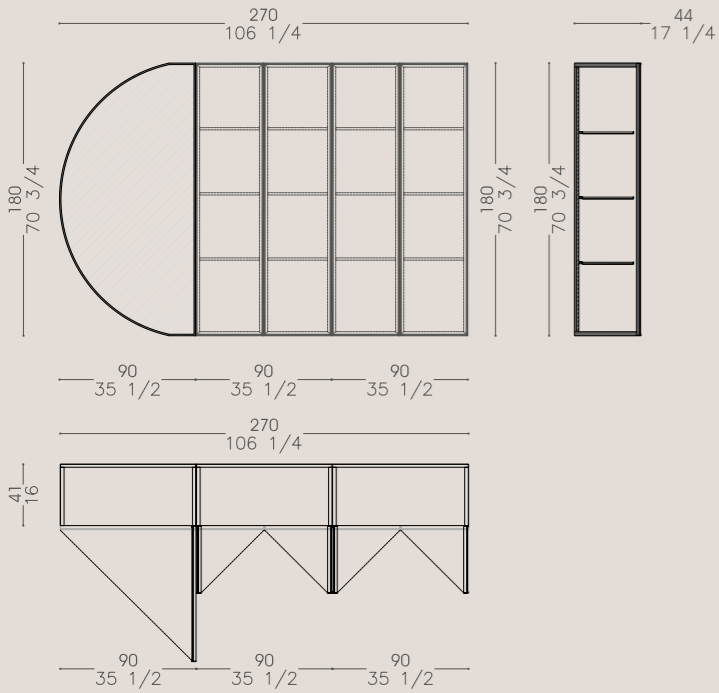

ante 45 cm h 180 cm p 43 cm | montaggio libero o ad incasso
doors 45 cm h 180 cm p 43 cm | freestanding or recessed mounting

VETRINA PICCOLA

small cabinet

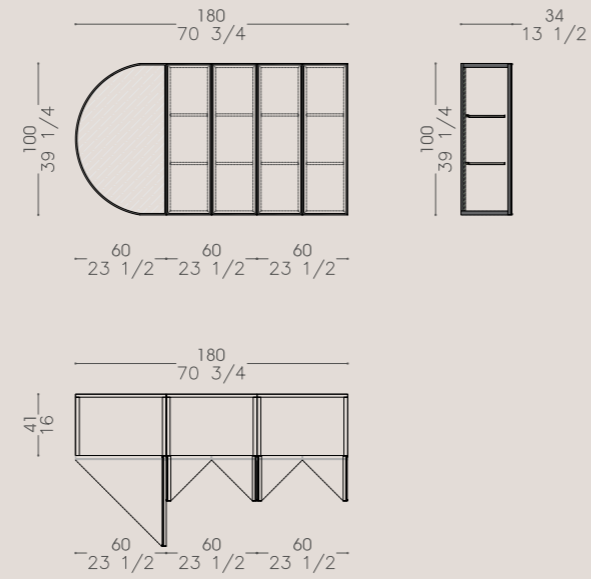

ante 30 cm h 100 cm p 33 cm | montaggio libero o ad incasso
doors 30 cm h 100 cm p 33 cm | freestanding or recessed mounting



TAVOLO MOBILE

mobile table

TAVOLO ROTONDO Ø 140 CM

round table Ø 140 cm

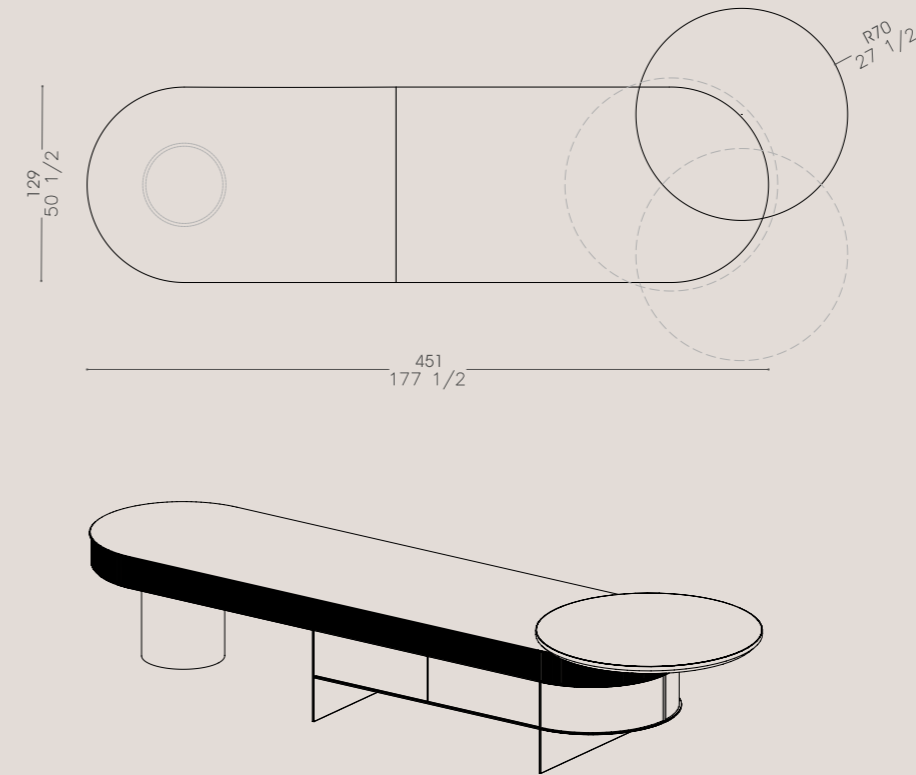

TAVOLO OVALE 217X104 CM

oval table 217x104 cm

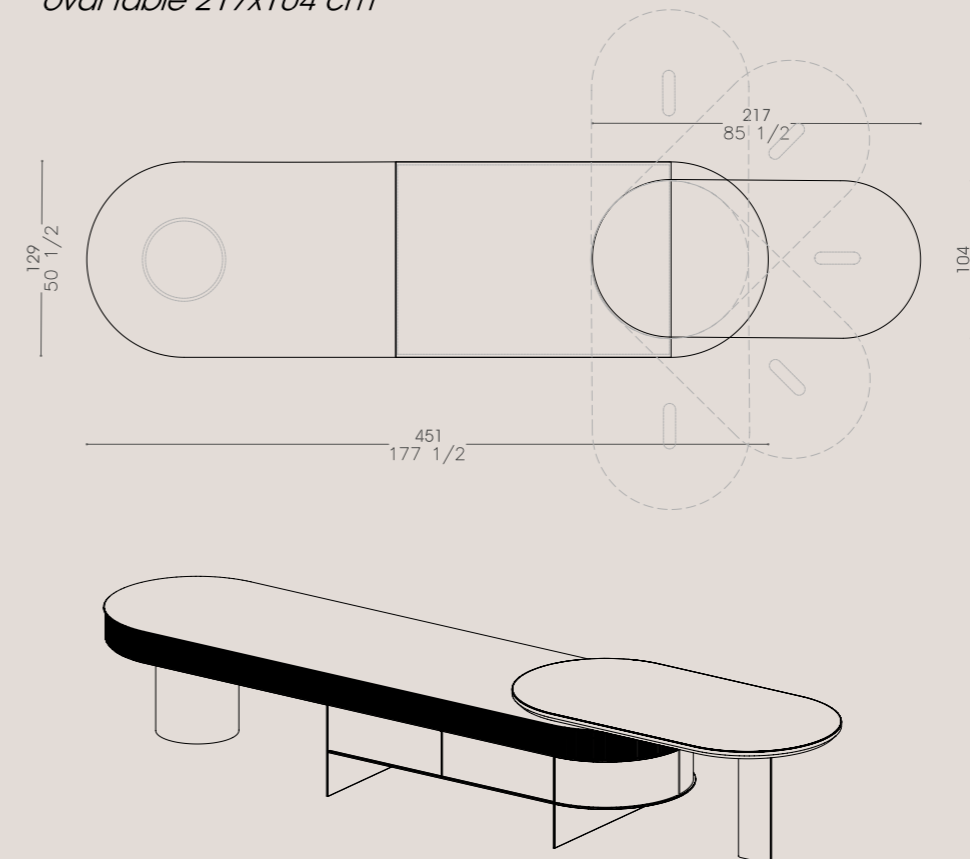

FINITURE
finishings

LEGNI
woods

LEGNO LUCIDO | polished wood

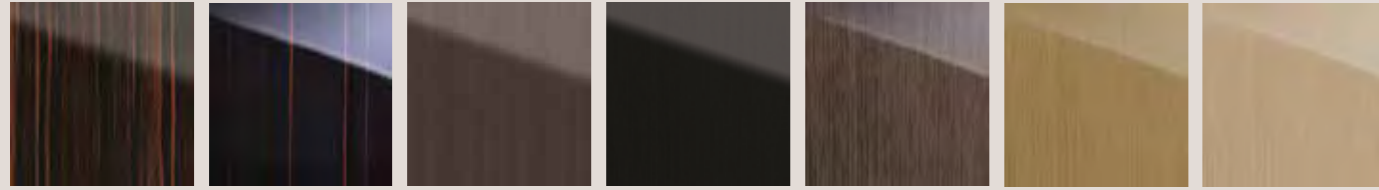

EBONY MACASSAR Macassar Ebony EBANO AMARA Ammara Ebony OLMO MOKA Elm Moka ROVERE NERO Black Oak ROVERE GRIGIO Grey Oak ROVERE MIELE Honey Oak ROVERE SABBIA Sand Oak

LEGNO OPACO | matt wood



EBONY MACASSAR Macassar Ebony EBANO AMARA Ammara Ebony OLMO MOKA Elm Moka ROVERE NERO Black Oak ROVERE GRIGIO Grey Oak ROVERE MIELE Honey Oak ROVERE SABBIA Sand Oak

LACCATURE
lacquers

LACCATURE LUCIDE | polished lacquers

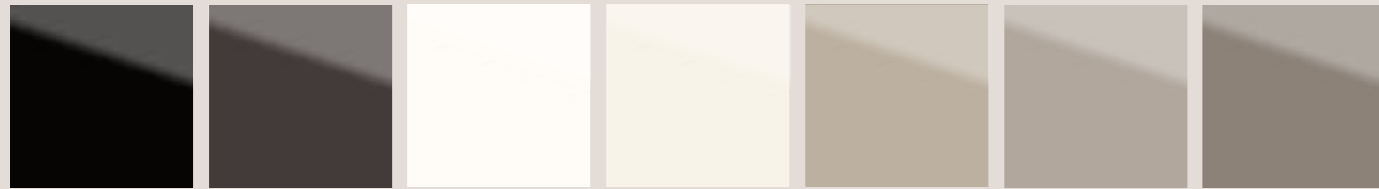

NERO black CACAO cacao BIANCO white AVORIO ivory LINO linen TORTORA taupe CAPPUCCINO cappuccino



PERLA pearl SALVIA sage LAGUNA lagoon PETROLIO petroleum PIOMBO lead

LACCATURE OPACHE | matte lacquers

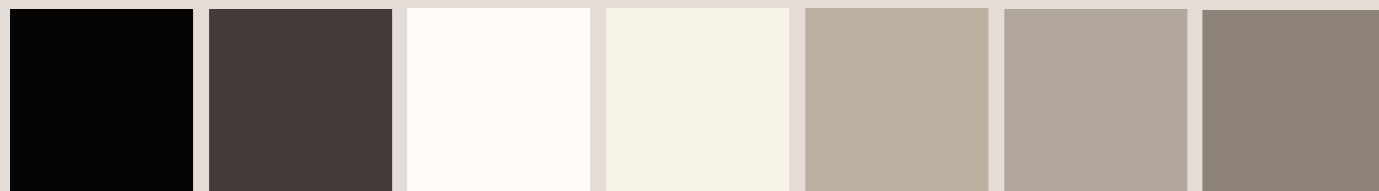

NERO black CACAO cacao BIANCO white AVORIO ivory LINO linen TORTORA taupe CAPPUCCINO cappuccino



PERLA pearl SALVIA sage LAGUNA lagoon PETROLIO petroleum PIOMBO lead

FINITURE
finishings

LACCATURE METALLIZZATE
metallic lacquers

LACCATURE LUCIDE METALLIZZATE | polished metallic lacquers

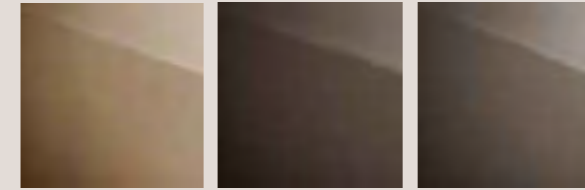

GRIGIO CENERE ash grey LAVA lava grey VULCANO volcano grey

LACCATURE METALLICHE OPACHE | matte metallic lacquers



GRIGIO CENERE ash grey LAVA lava grey VULCANO volcano grey

METALLI
metals

METALLI LUCIDI | polished metals

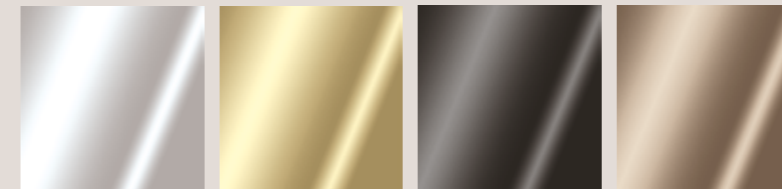

CROMO chrome CHAMPAGNE champagne NICHEL NERO black nickel BRONZO bronze

METALLI SATINATI | satin metals

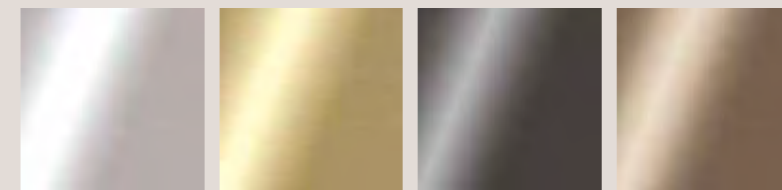

ACCIAIO iron CHAMPAGNE champagne NICHEL NERO black nickel BRONZO bronze

MARMI
marble

I TOP E I BACKSPASH DELLA CUCINA RIALTO POSSONO ESSERE REALIZZATI CON QUALSIASI QUALITÀ DI MARMO RICHIESTA
Rialto kitchen tops and backsplashes can be made with any quality of marble required

FINITURE
finishings

VETRITE



FINITURE
finishings

VETRITE

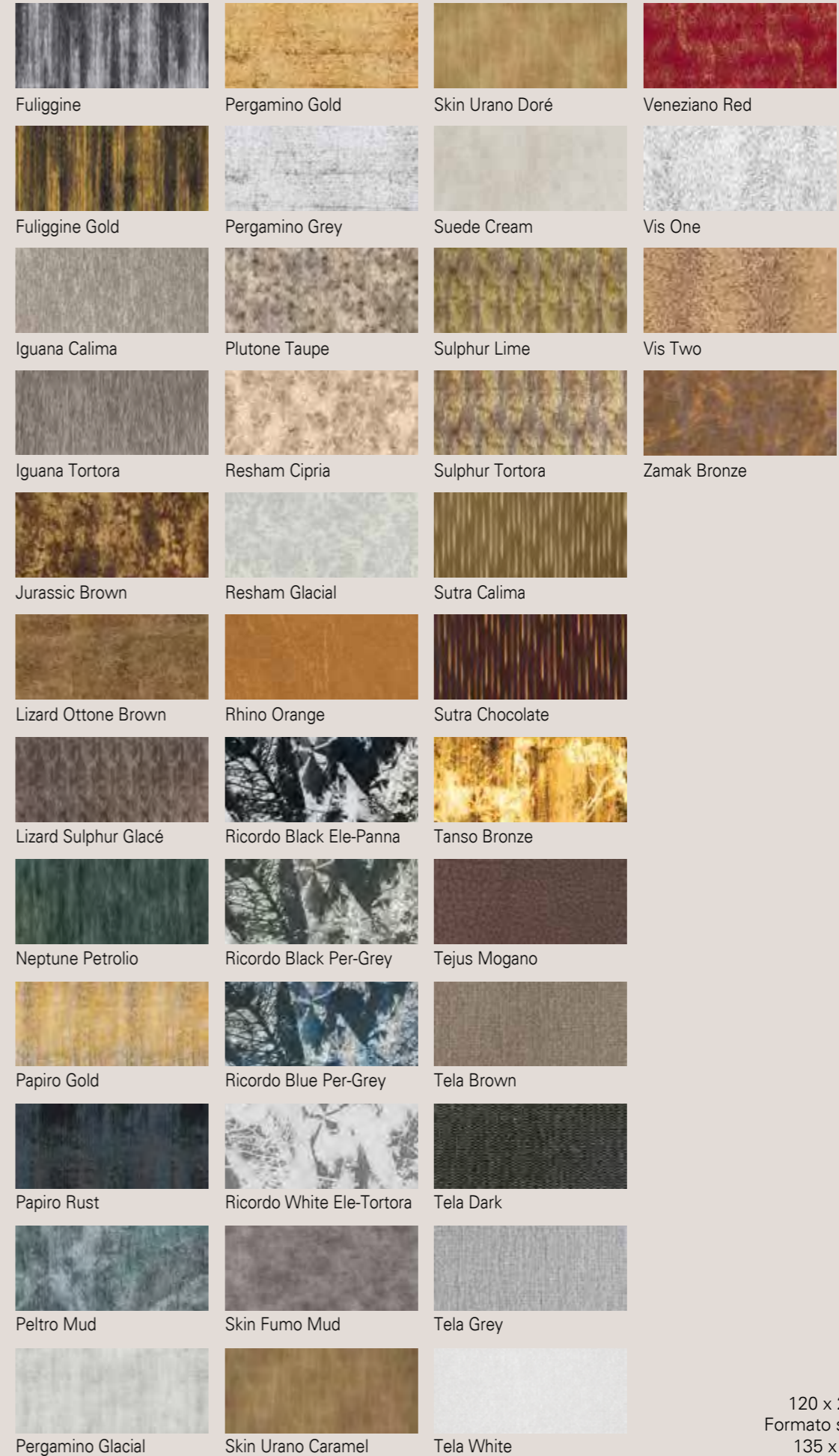

Formato - *Slab size*
120 x 280cm - 47 1/4" x 110 1/4"
Formato speciale - *Special slab size*
135 x 290cm - 53 1/8" x 114 1/8"

FINITURE
finishings

VETRITE GEM GLASS

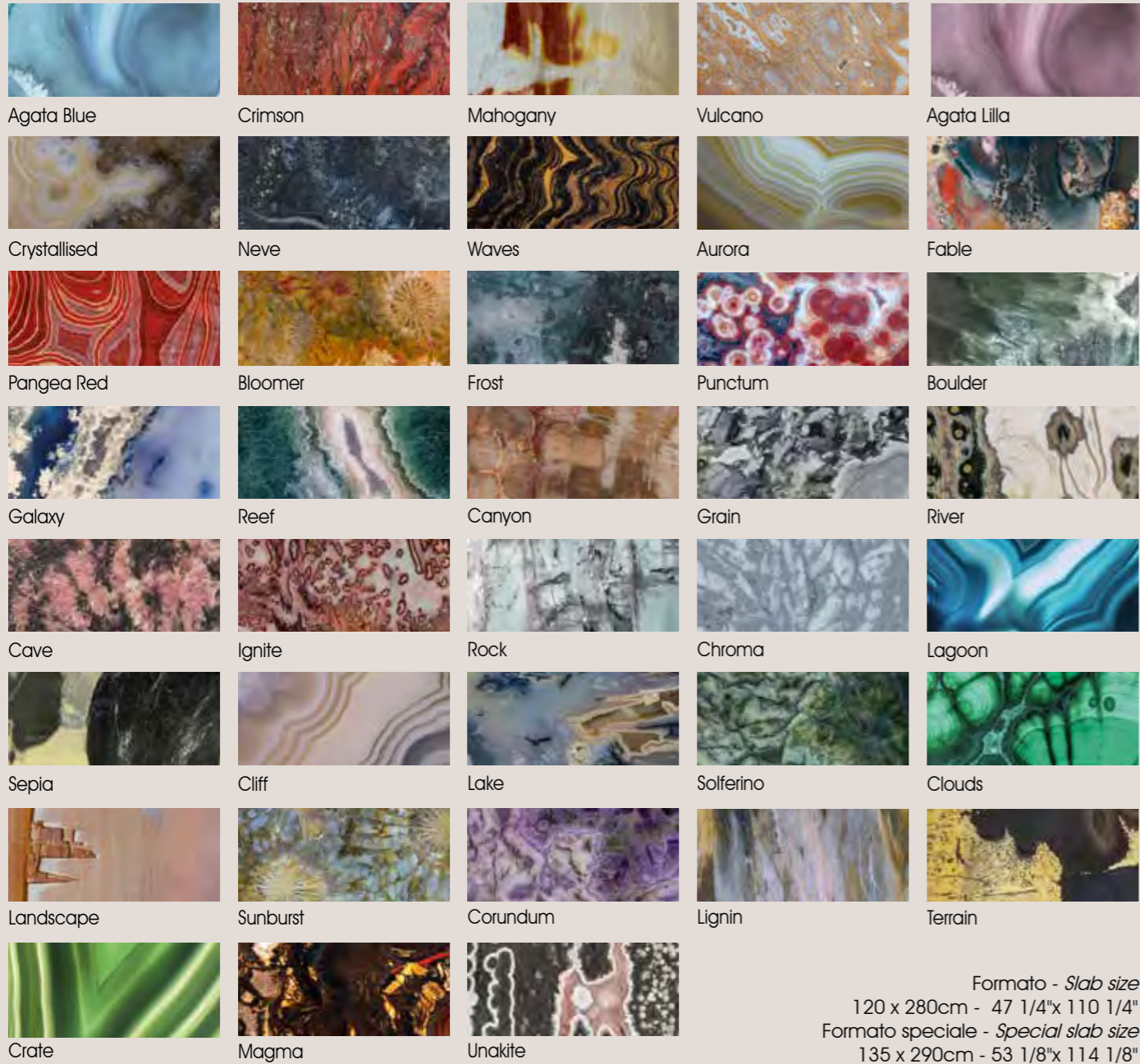

FINITURE
finishings

VETRITE SIGHT

















VETRITE - ELECTRIC MARBLE





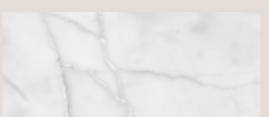









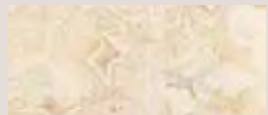

FINITURE
finishings

VETRITE - ONIGEM

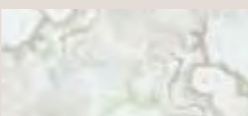
				
Avory	Bolt	Deep blue	Dusk	Emerald
				
Giada	Green	Honey	Mocha	Nebula
				
Ocean	Petroleum	Pink	Rice	Spider
				
Twilight				

Formato - *Slab size*
 120 x 280cm - 47 1/4"x 110 1/4"
 Formato speciale - *Special slab size*
 135 x 290cm - 53 1/8"x 114 1/8"

VETRITE - GEM STONE

				
Atlantic	Candy	Caramel	Confetti	Fantasy
				
Maracuja	Messier	Mineral	Noire	Olimpus
				
Pacific	Salty Dew	Stalagmite	Streetwalk	Tropical
				
Will				

Formato - *Slab size*
 120 x 280cm - 47 1/4"x 110 1/4"
 Formato speciale - *Special slab size*
 135 x 290cm - 53 1/8"x 114 1/8"



TUTTI GLI ARREDI E LE LAMPADE PRESENTI NEL CATALOGO FANNO PARTE DELLA COLLEZIONE SICIS HOME E SICIS LIGHTING
all the furnishings and lamps in the catalog are part of the sicis home and sicis lighting collection



VETRITE
Go to the WebSite



SICIS
HOME COLLECTION
Go to the WebSite



SICIS
LIGHTING COLLECTION
Go to the WebSite

BACKSPLASH



IL BACKSPLASH A RICHIESTA DEL CLIENTE PUO' ESSERE PERSONALIZZATO CON RIVESTIMENTO IN MOSAICO ARTISTICO O VETRITE DECORATE

The backsplash can be customized according to the client's request customized with artistic mosaic coating or decorated glass panels



Corte



Sauvage



Garden



Ortiga



Bon Ton



Marrakesh



LEGAL NOTICE

By retaining this SICIS catalogue, you acknowledge and agree to the following:

This catalogue is and remains the property of SICIS s.r.l. ("SICIS").

SICIS reserves the right, at any time, to request the return of this catalogue.

The catalogue is provided to you FREE OF CHARGE and is NOT FOR RESALE. If you paid for this catalogue, please write to SICIS at the address provided below.

Copyright laws protect the content of this catalogue, including, without limitation, the photographs, images, text, layout and designs contained therein.

The reproduction or copying of any part of this catalogue, including, without limitation, the photographs, images, text, layout and designs contained therein, IS PROHIBITED, and legal action may be commenced against anyone, including, but not limited to, yourself, who violates this prohibition.

By giving you a copy of this catalogue, SICIS is not thereby giving you any license, either implied or express, to reproduce or copy it or any parts of it, in any way.

The trademark SICIS® is a registered trademark and the property of SICIS s.r.l., and is protected under domestic and international laws.

SICIS reserves all its rights and remedies.

AVVISO LEGALE

Ricevendo il presente catalogo SICIS, prendi atto ed accetti i seguenti termini e condizioni:

Il presente catalogo è e rimane di proprietà di SICIS s.r.l. ("SICIS").

SICIS si riserva il diritto, in qualsiasi momento, di richiederne la restituzione.

Il catalogo è fornito a TITOLO GRATUITO e NON ne è AUTORIZZATA LA RIVENDITA. Se hai dovuto pagare per questo catalogo, ti preghiamo di segnalarcelo scrivendoci all'indirizzo riportato di seguito.

Le leggi in materia di diritto d'autore (Copyright) proteggono il contenuto del presente catalogo, inclusi, senza alcuna limitazione, le fotografie, immagini, testi, layout ed i disegni in esso contenuti.

La riproduzione o la copia di qualsiasi parte del presente catalogo, inclusi, senza alcuna limitazione, le fotografie, immagini, testi, layout ed i disegni in esso contenuti, È VIETATA, e SICIS si riserva il diritto di intraprendere azione legale nei confronti di chiunque (incluso te) violi il presente divieto.

L'aver ricevuto una copia del presente catalogo, non dà diritto in alcun modo ad alcuna licenza da parte di SICIS, né implicita né tantomeno espressa, di riprodurre o copiare, in qualsiasi modo o forma, alcuna parte di esso.

Il marchio SICIS® è un marchio registrato e di proprietà della SICIS s.r.l., ed è protetto dalle leggi nazionali ed internazionali in materia.

SICIS espressamente si riserva tutti i diritti e rimedi.

www.sicis.com · info@sicis.com
SICIS · Sede Legale · Via Borgonuovo, 29 · 20121 Milano (Italy)
Sicis s.r.l. Ravenna (Italy) - June 2021

© 2024 Sicis S.r.l.
SICIS® is trademark of Sicis S.r.l.
SICIS® è un marchio di Sicis S.r.l.

SICIS ITALY

Showroom Milano

20121 · Via Fatebenefratelli, 8

Ph. +39 02 87 60 99

Showroom & Factory Ravenna (Italy)

48123 · Via Canala, 85

Ph. +39 0544 469 711 · Fax +39 0544 46 98 11

SICIS FRANCE

Showroom Paris

19 rue Marbeuf 75008 Parigi

Ph. +33 01 49 52 89 89

SICIS UNITED KINGDOM

Showroom & Offices London

15A Dover St, Mayfair, W1S 4LR

Ph. +44 207 491 9849

SICIS SWISS

Sicis Store S'Antonino

Via Stazione 23 - 6592 Sant'Antonino - (CH)

Ph. +41 91 985 34 57

SICIS NORTH AMERICA

Corporate Headquarters New York

150 Bruckner Blvd, Bronx 10454

Ph. 212 965 4100

877 839 8900 (Toll Free)

SICIS ME

Showroom Dubai

57RW+4MR - Dubai Design District - Dubai

United Arab Emirates

Ph. +971 50 5270183

SICIS®

www.sicis.com
made in Italy

